

Yoga4 SKL-U CS SIT2 Schematic Block Diagram

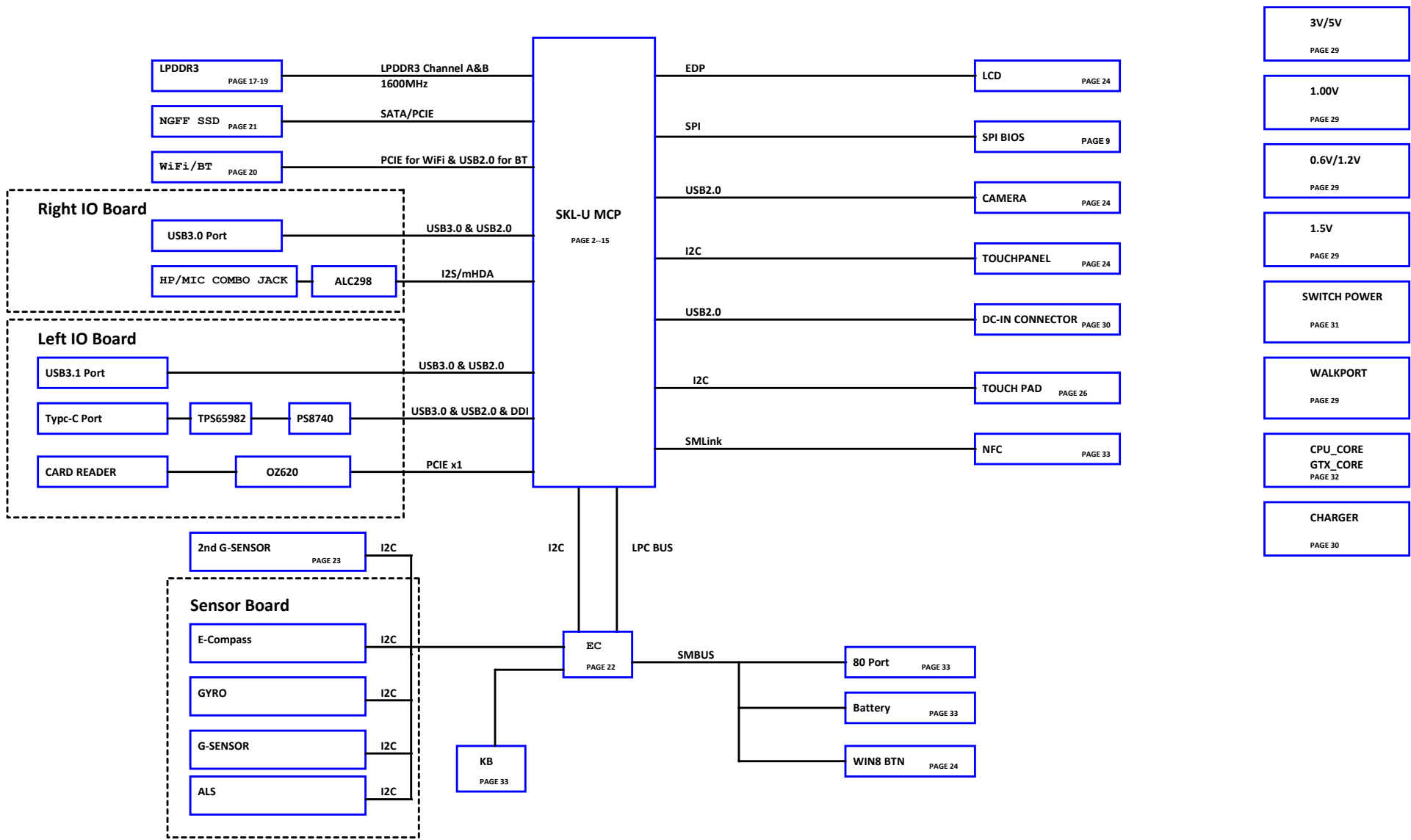

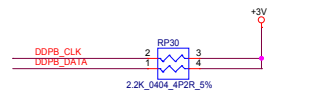

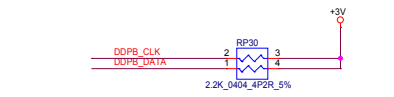
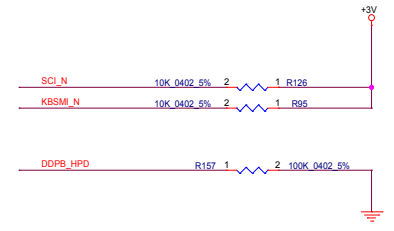
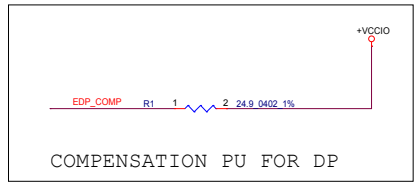
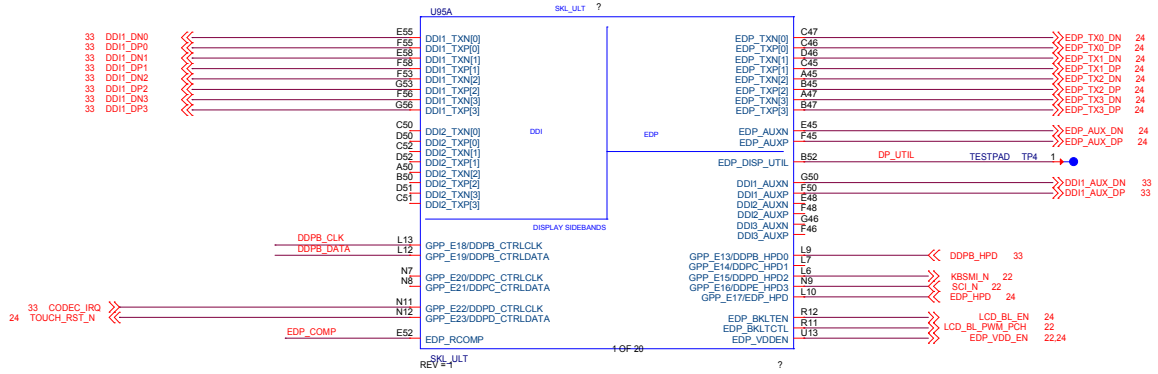
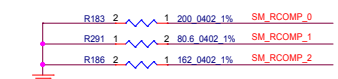
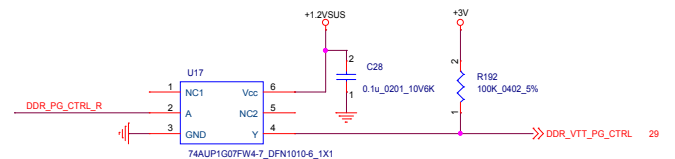
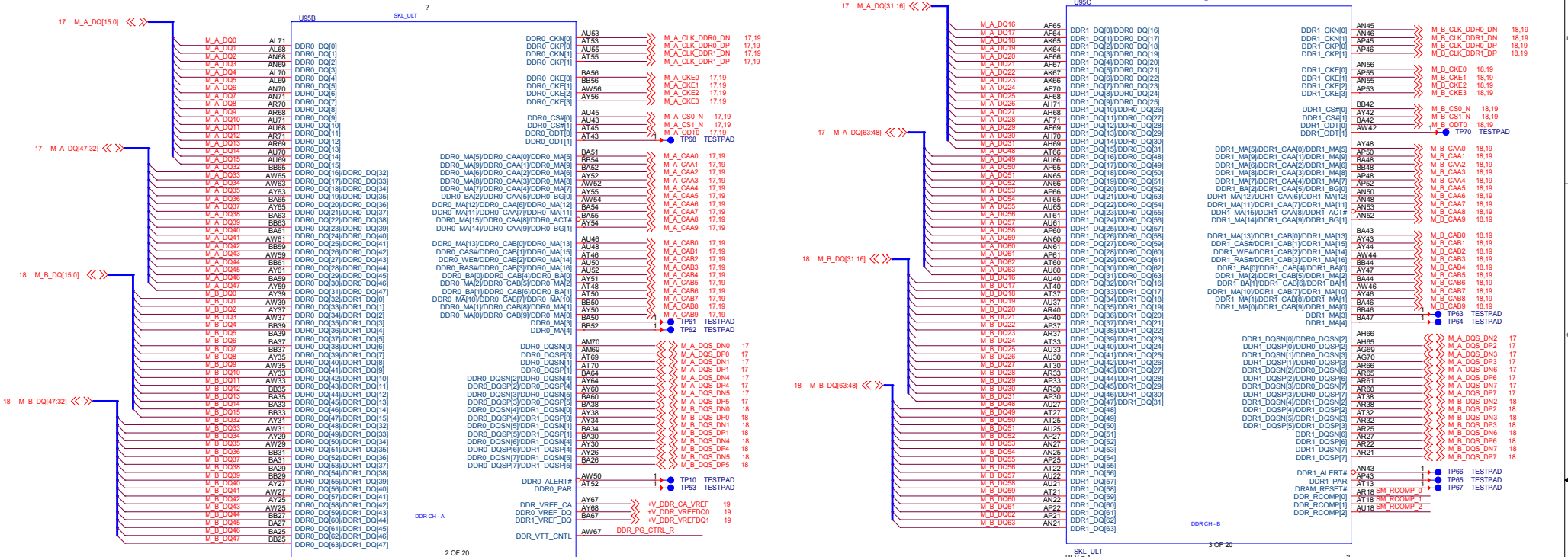

lenovo LENOVO.CRDN

BROADWELL MCP (PROCESSOR LPDDR3)

Size	Document Number	Rev
C	YOGA4	V1.0

Date: Monday, July 27, 2015 Sheet 3 of 37

PROPERTY NOTE: This document contains information confidential and proprietary to LENOVO PND and shall not be reproduced or transferred to other documents or disclosed to others or used for any purpose other than that for which it was obtained without the expressed written consent of LENOVO PND.

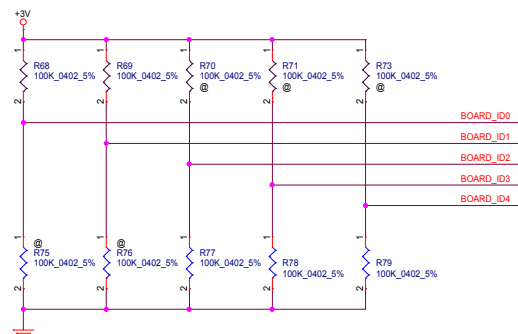
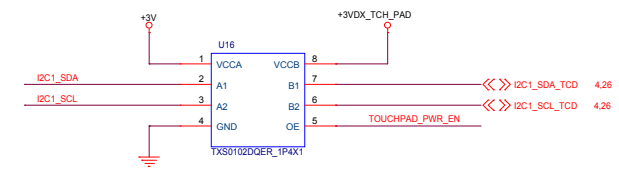
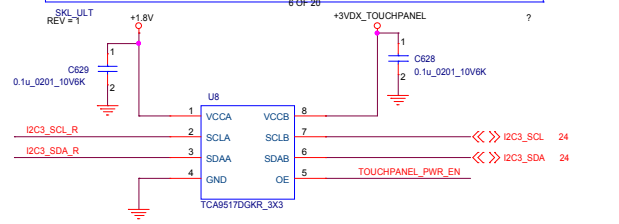
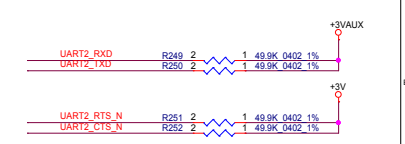
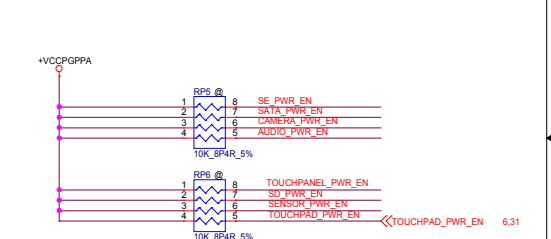
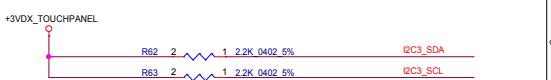
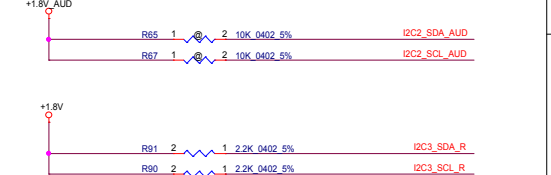
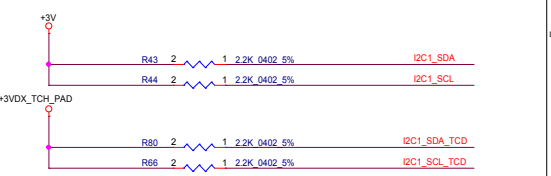
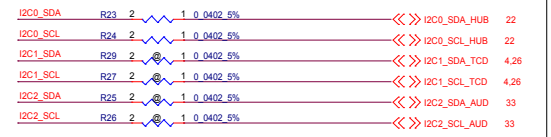
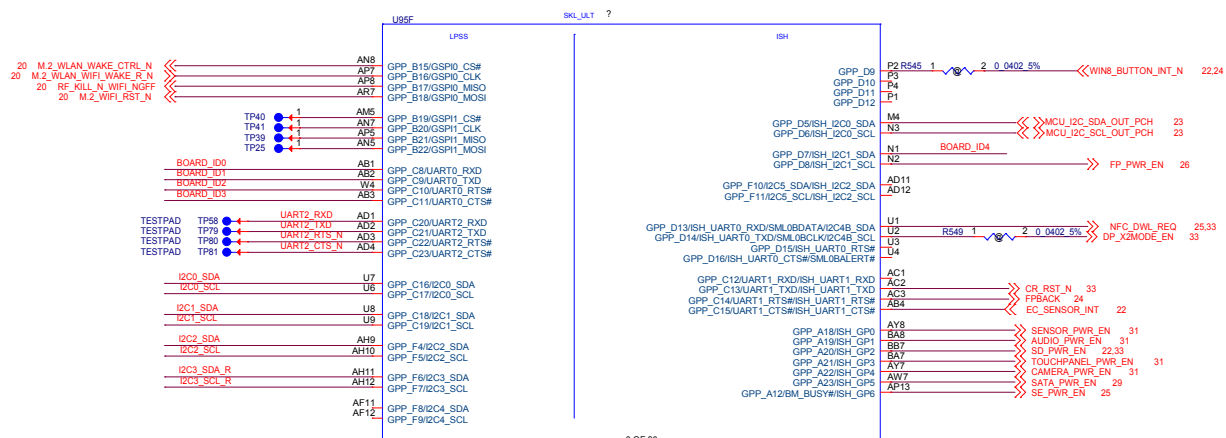

SDV

BOARD_ID4	BOARD_ID3	BOARD_ID2	BOARD_ID1	BOARD_ID0	Description
0	0	0	0	0	Elpida LPDDR3 16Gb 1600
0	0	0	0	1	Samsung LPDDR3 16G 1600
0	0	0	1	0	Elpida LPDDR3 8Gb 1600
0	0	0	1	1	Micron LPDDR3 32Gb 1866
0	0	1	0	0	Hynix LPDDR3 16Gb 1600
0	0	1	0	1	Samsung LPDDR3 8Gb 1600

SLV

BOARD_ID4	BOARD_ID3	BOARD_ID2	BOARD_ID1	BOARD_ID0	Description
0	0	1	1	0	Micron 16Gb x32 LPDDR3 1866
0	0	1	1	1	Hynix 16Gb x32 LPDDR3 1866
0	1	0	0	0	Samsung 16Gb x32 LPDDR3 1866
0	1	0	0	1	Hynix 8Gb x32 LPDDR3 1866
0	1	0	1	0	Samsung 8Gb x32 LPDDR3 1866
0	1	0	1	1	Hynix 32Gb x32 LPDDR3 1866
0	1	1	0	0	Micron 8Gb x32 LPDDR3 1866
0	1	1	0	1	Samsung 32Gb x32 LPDDR3 1866

lenovo 联想 LENOVO.CRDN

Title BROADWELL MCP (PCIe USB GPIO)

Size C Document Number YOGA4 Rev V1.0

Date Monday, July 27, 2015 Sheet 4 of 37

PROPERTY NOTE: This document contains information confidential and property to LENOVO PND and shall not be reproduced or transferred to other documents or disclosed to others or used for any purpose other than that for which it was obtained without the expressed written consent of LENOVO PND.

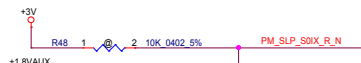

Wlan
Card Reader



SATA PORT2

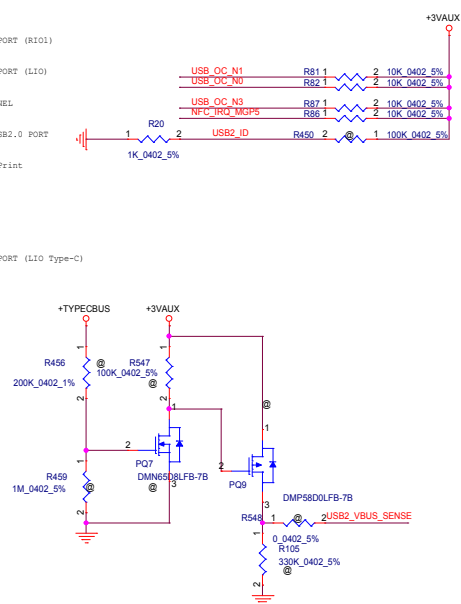
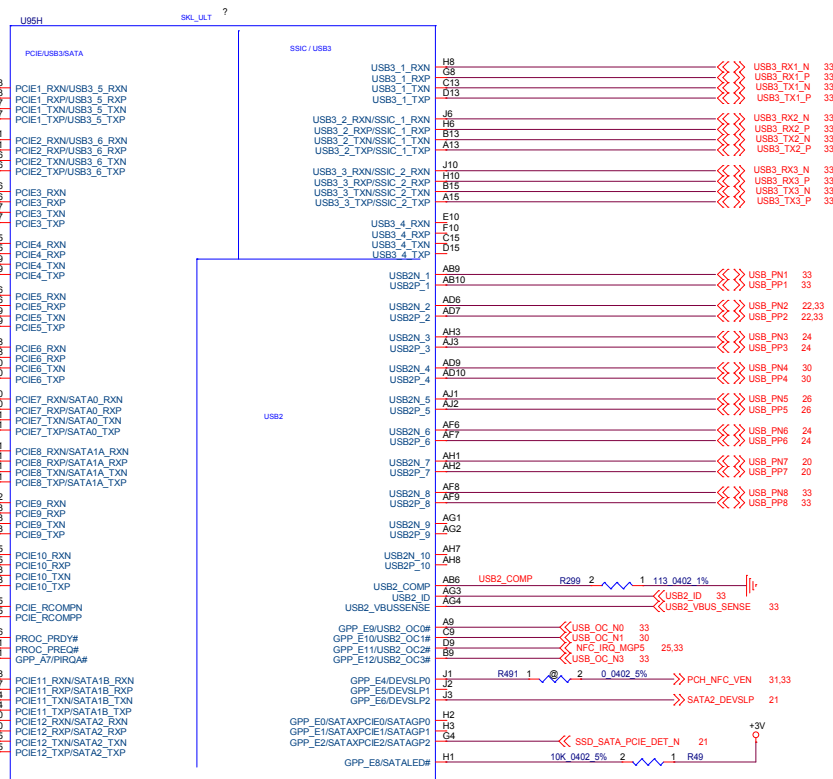
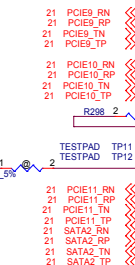

lenovo 联想 LENOVO.CRDN

BROADWELL MCP (PCIE USB GPIO)

Size C Document Number YOGA4 Rev V1.0

Date: Monday, July 27, 2015 Sheet 5 of 37

PROPERTY NOTE: This document contains information confidential and proprietary to LENOVO PND and shall not be reproduced or transferred to other documents or disclosed to others or used for any purpose other than that for which it was obtained without the expressed written consent of LENOVO PND.

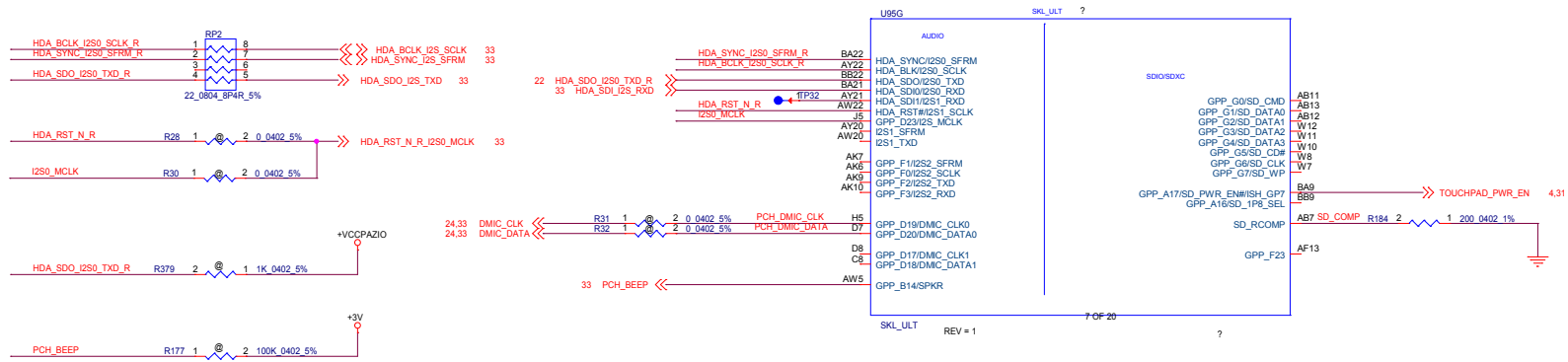

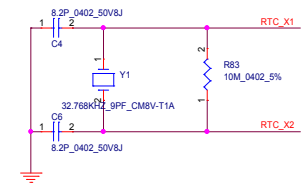
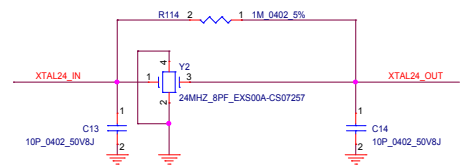
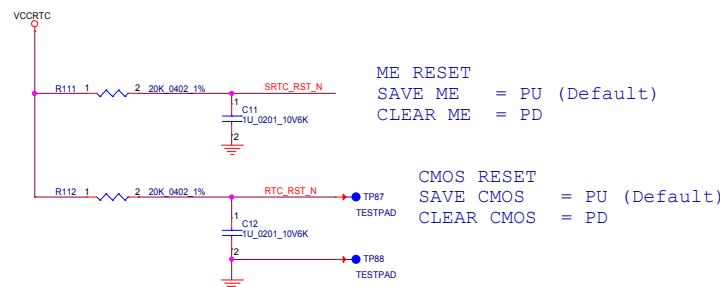
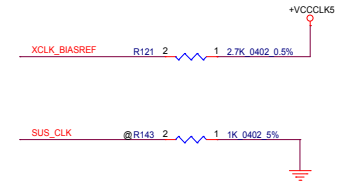
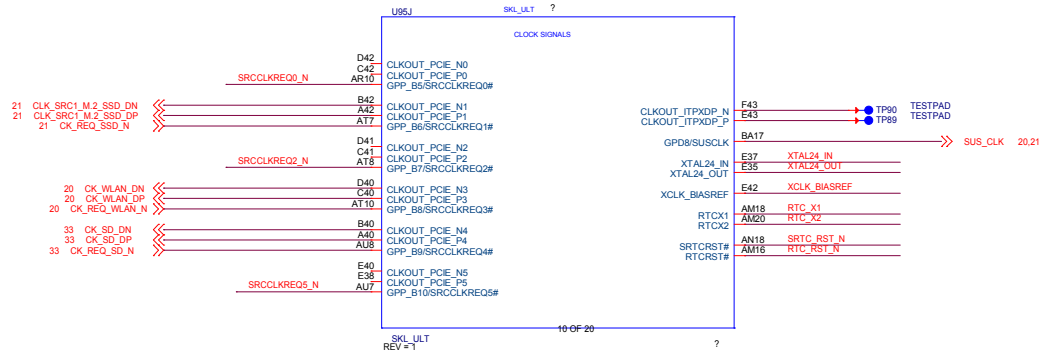
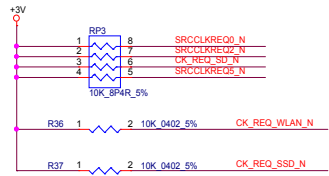

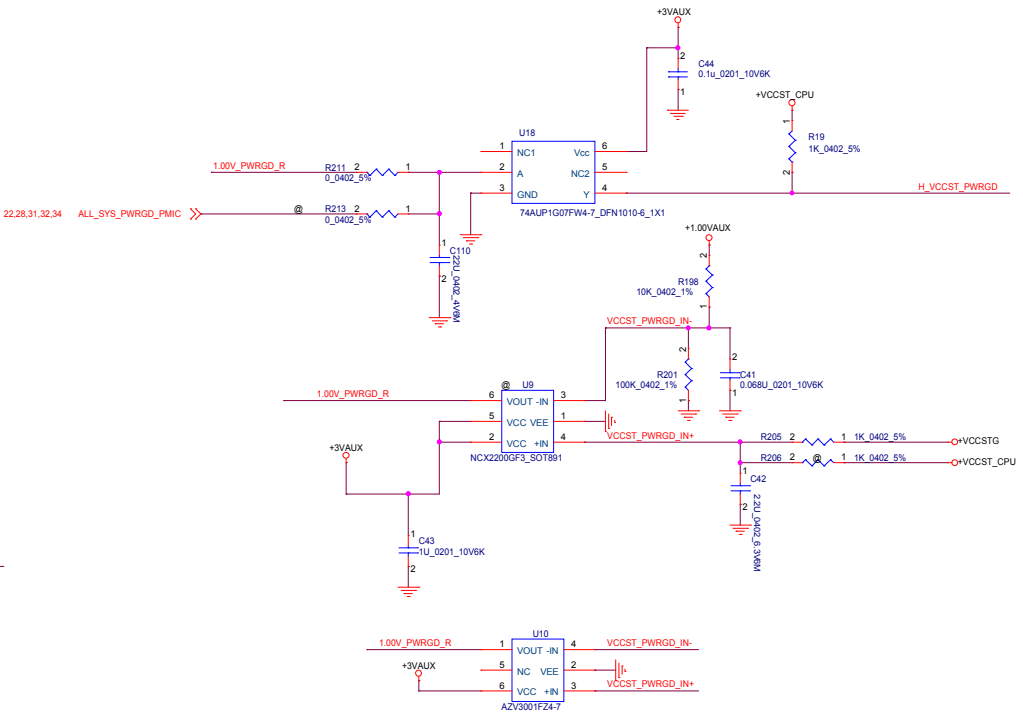
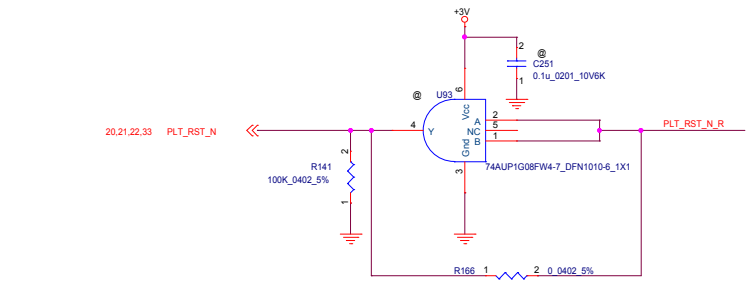
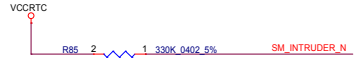
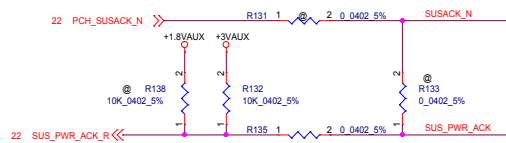
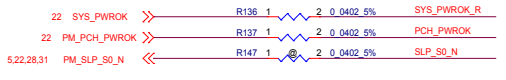
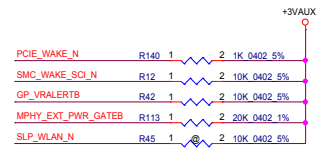
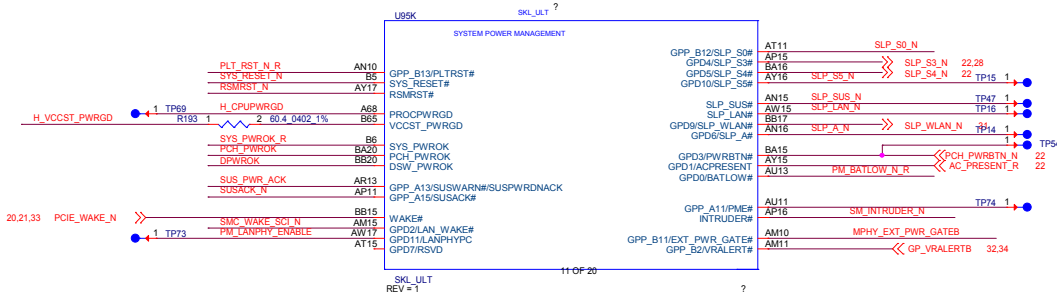
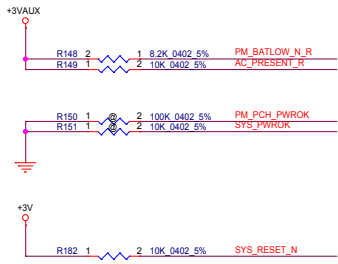

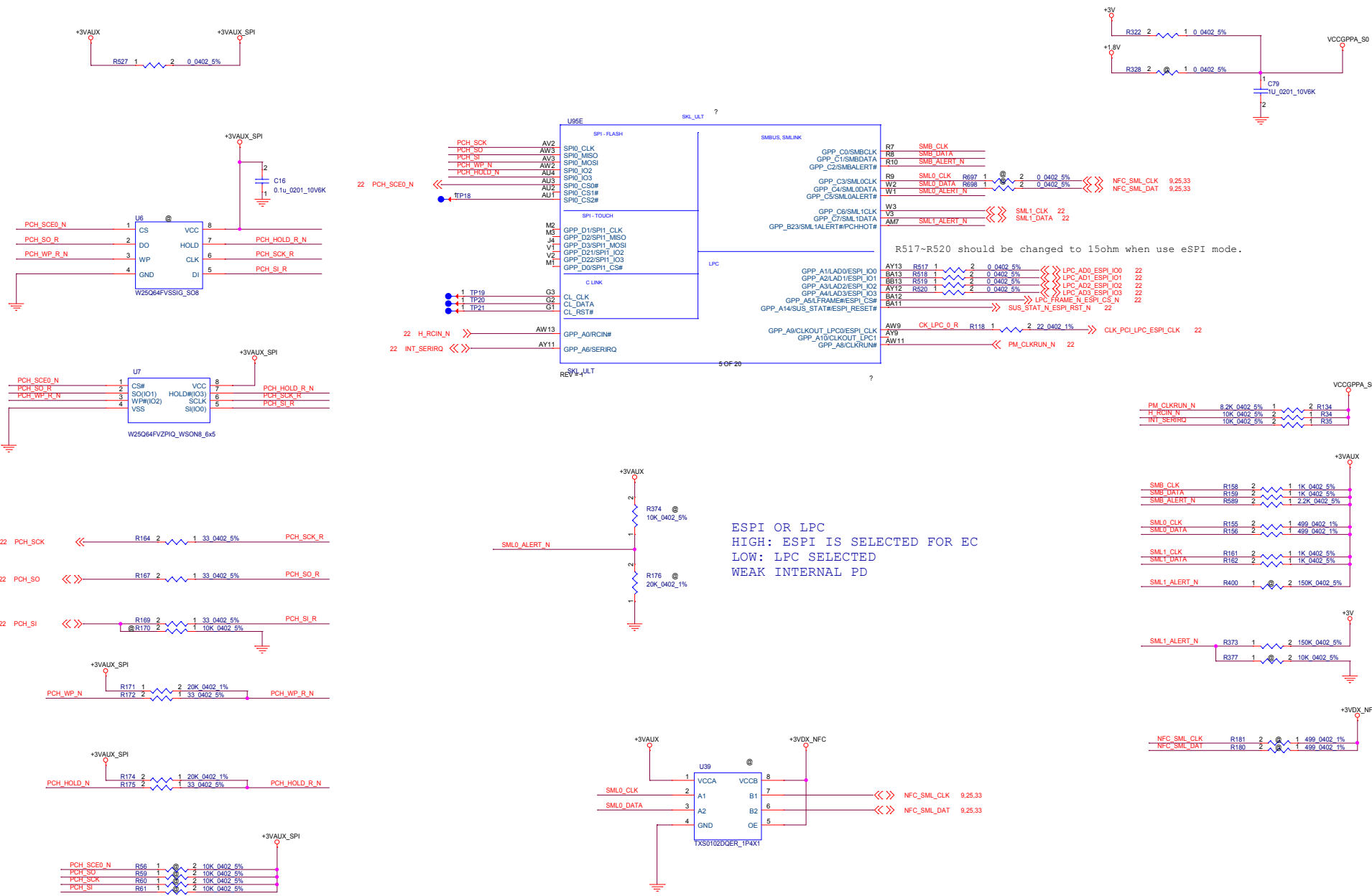

ESPI OR LPC
 HIGH: ESPI IS SELECTED FOR EC
 LOW: LPC SELECTED
 WEAK INTERNAL PD

R517~R520 should be changed to 15ohm when use eSPI mode.

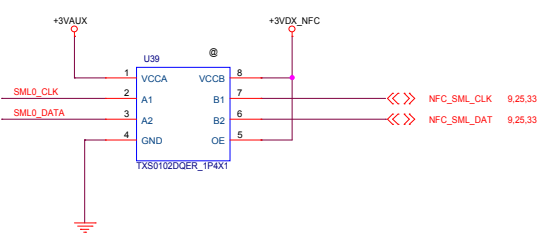
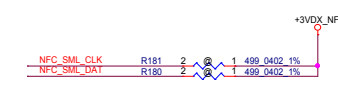
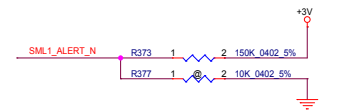
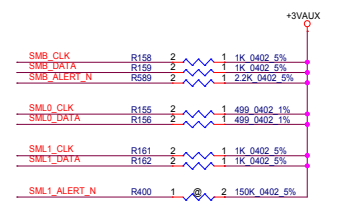
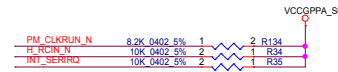

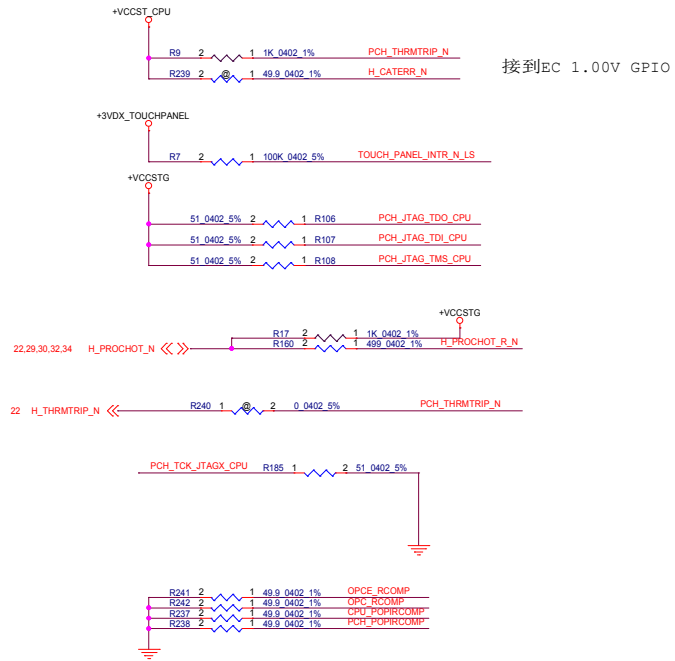

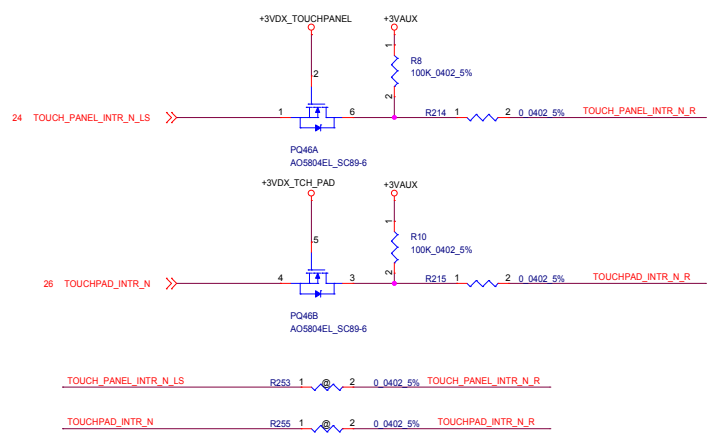
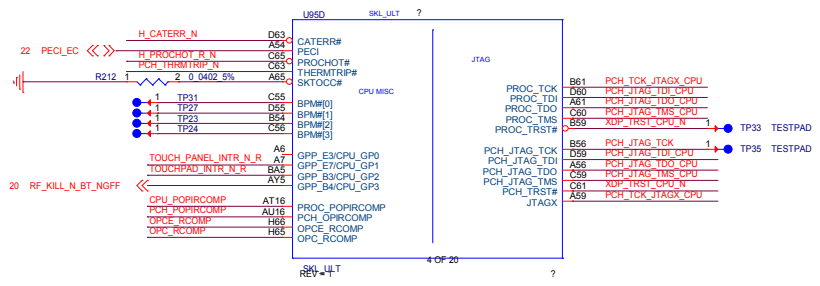

接到EC 1.00V GPIO

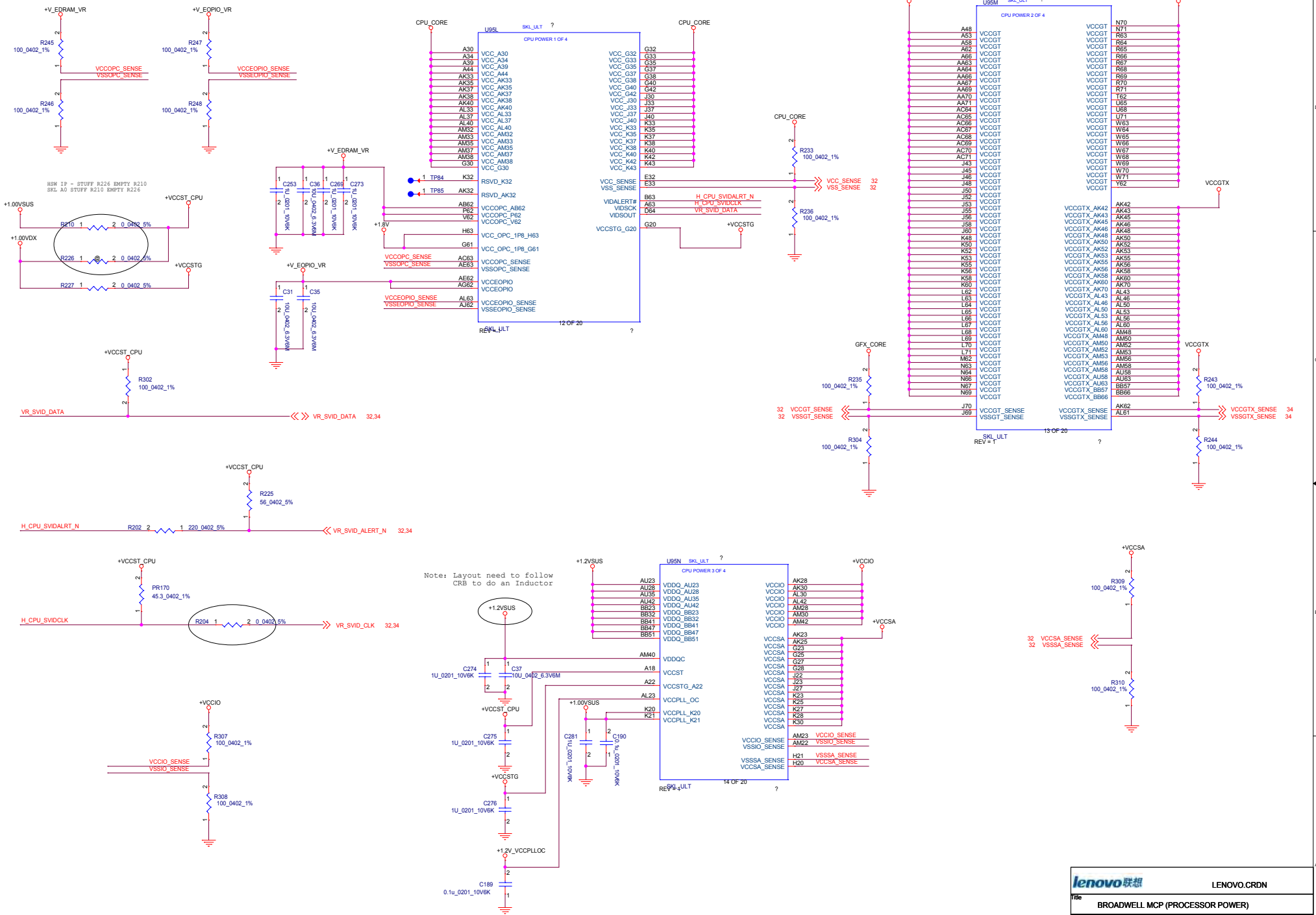

lenovo 联想		LENOVO.CRDN	
Title BROADWELL MCP (MISC THERM CPU JTAG)			
Size C	Document Number YOGA4	Sheet 10	of 37
Date Monday, July 27, 2015	Rev V1.0	Rev V1.0	
PROPERTY NOTE: this document contains information confidential and property to LENOVO PND and shall not be reproduced or transferred to other documents or disclosed to others or used for any purpose other than that for which it was obtained without the expressed written consent of LENOVO PND.			

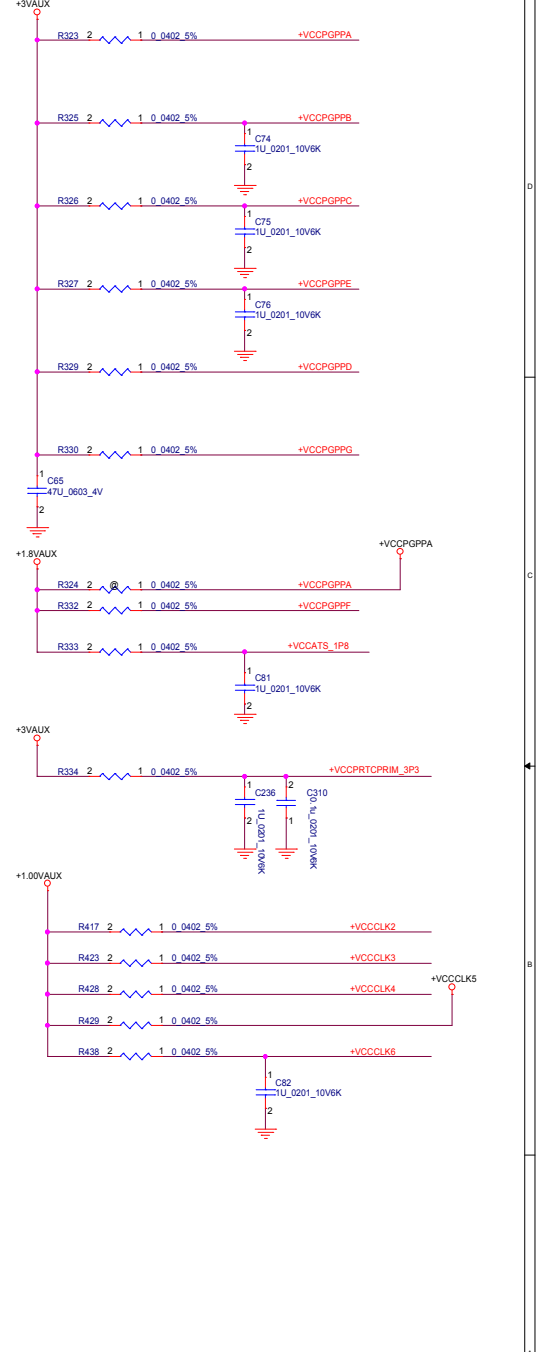
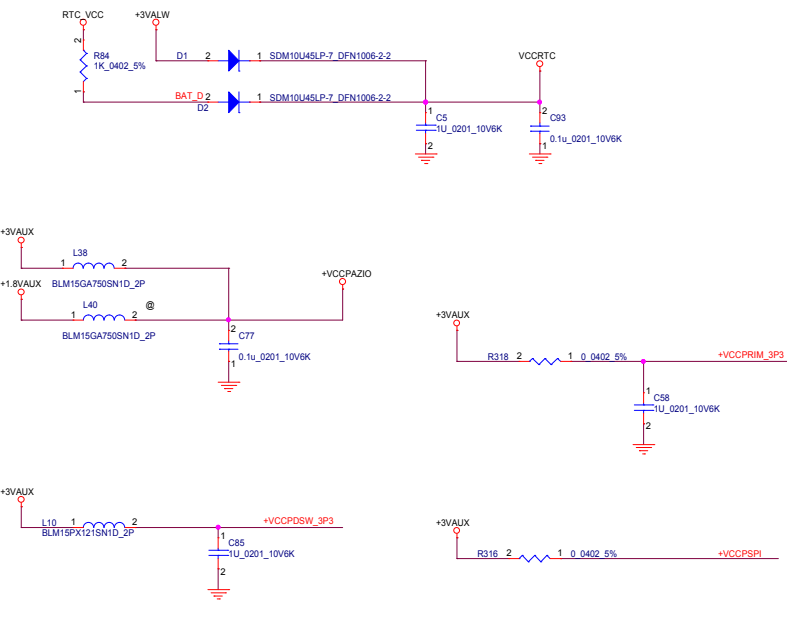
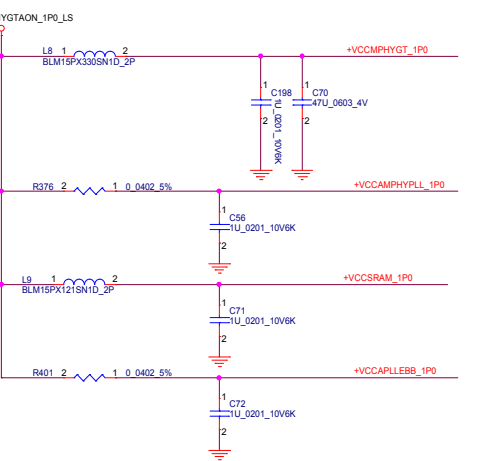
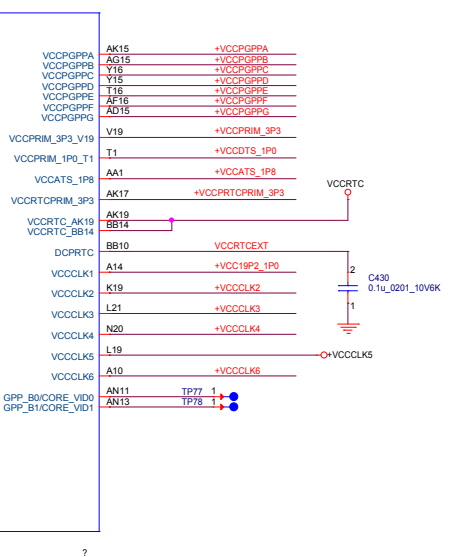
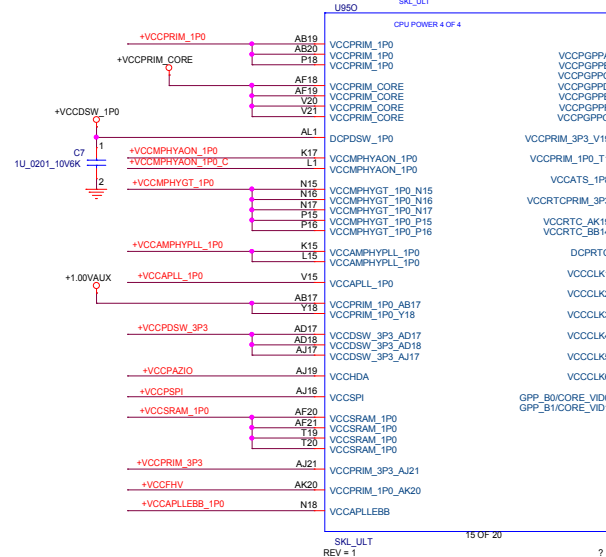
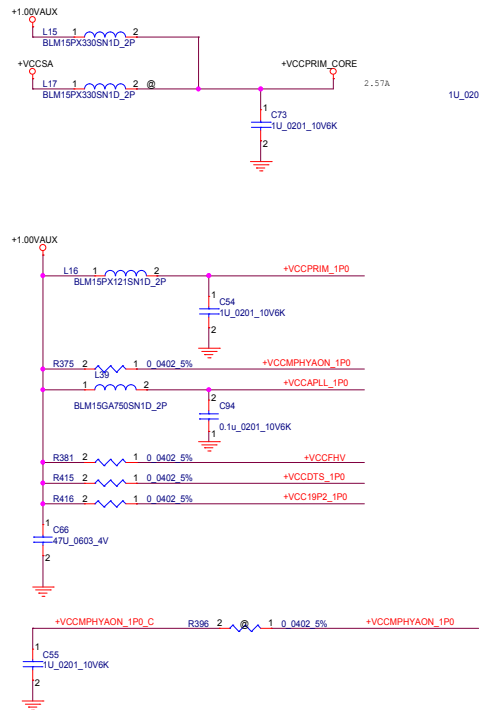





LENOVO.CRDN

BROADWELL MCP (PCH POWER)

Size C	Document Number YOGA4	Rev V1.0
--------	-----------------------	----------

Date: Monday, July 27, 2015 Sheet 12 of 37

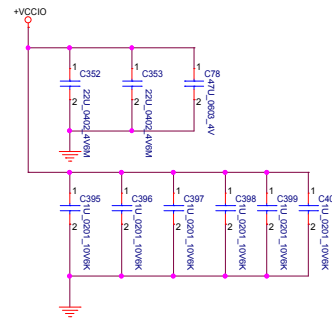
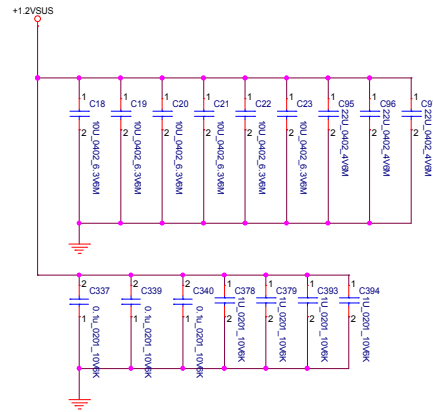
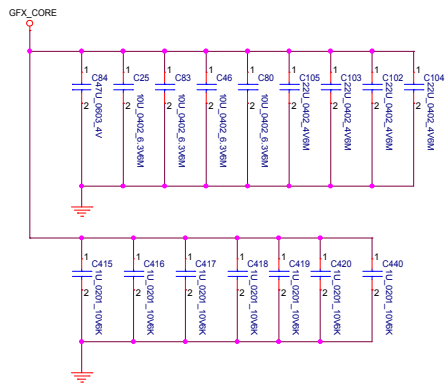
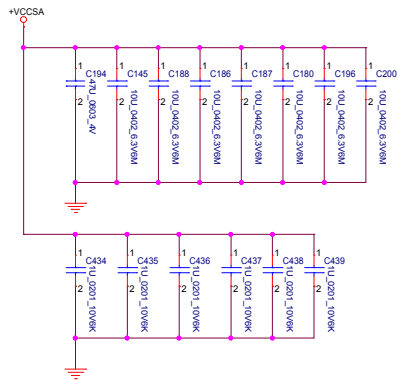
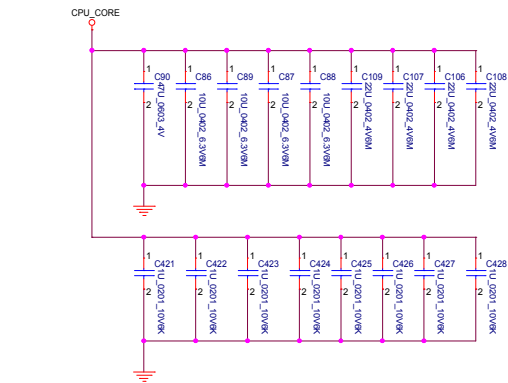
PROPERTY NOTE: This document contains information confidential and property to LENOVO PND and shall not be reproduced or transferred to other documents or disclosed to others or used for any purpose other than that for which it was obtained without the expressed written consent of LENOVO PND.*



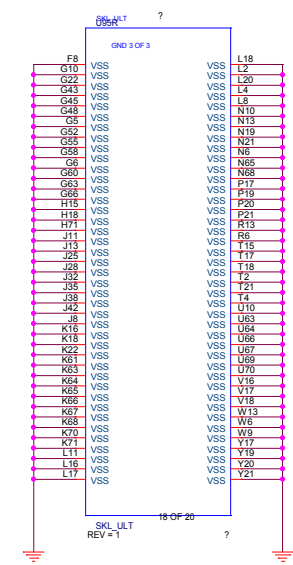
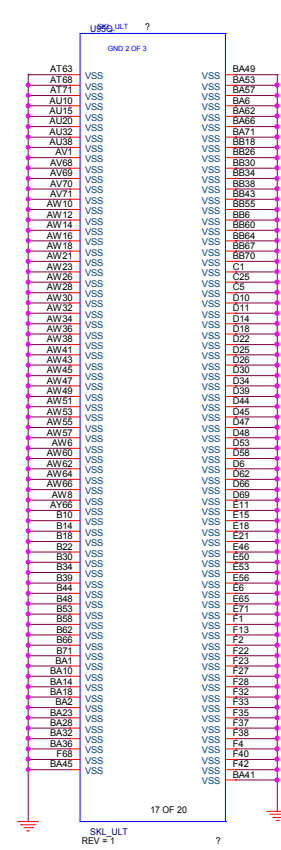
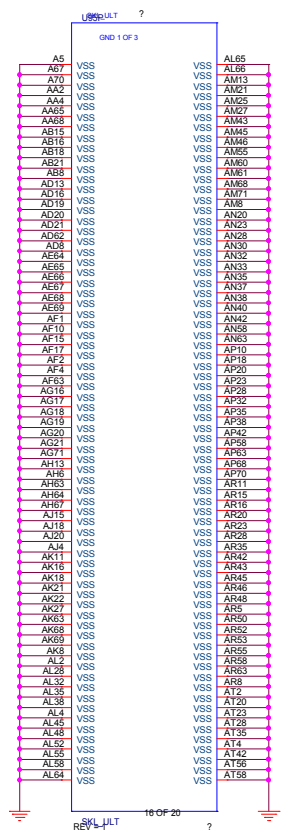

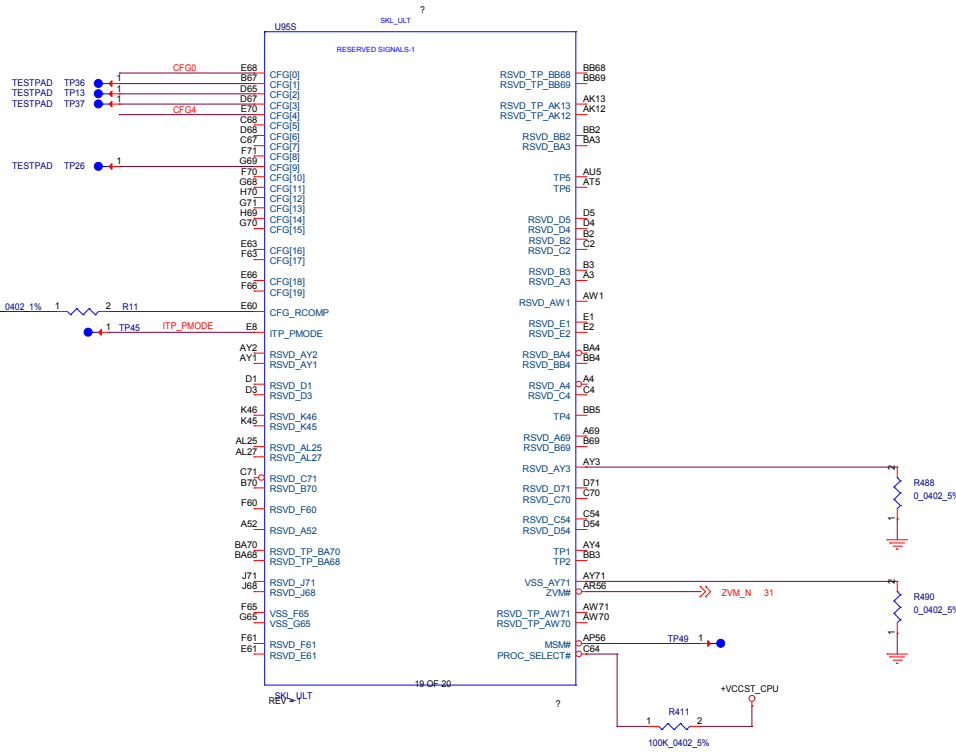
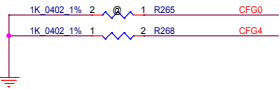
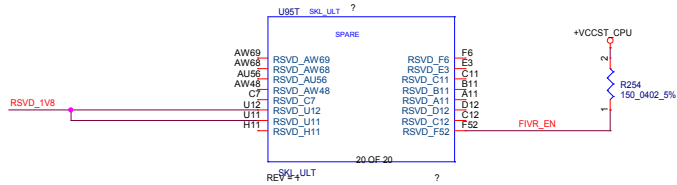

5

4

3

2

1

D

D

C

C

B

B

A

A

		LENOVO.CRDN	
Title			
XXXXX			
Size	Document Number	Rev	
C	YOGA4	16	37 V1.0
Date: Monday, July 27, 2015		Sheet	16 of 37
<small>PROPERTY NOTE: this document contains information confidential and property to LENOVO PND and shall not be reproduced or transferred to other documents or disclosed to others or used for any purpose other than that for which it was obtained without the expressed written consent of LENOVO PND.*</small>			

5

4

3

2

1

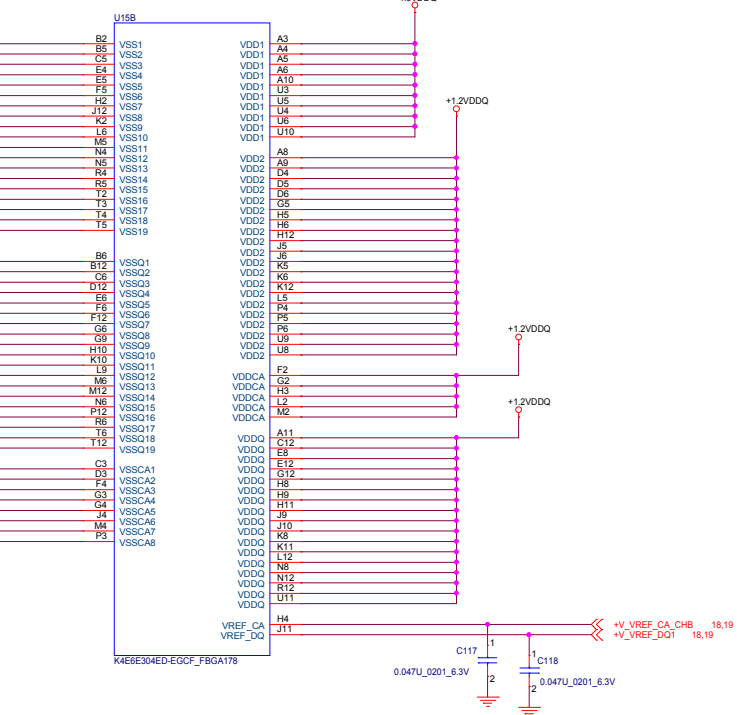
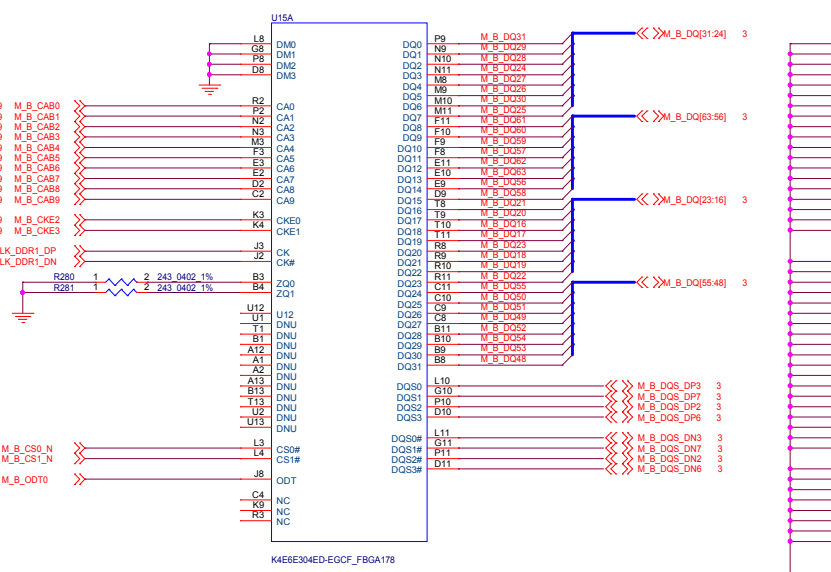
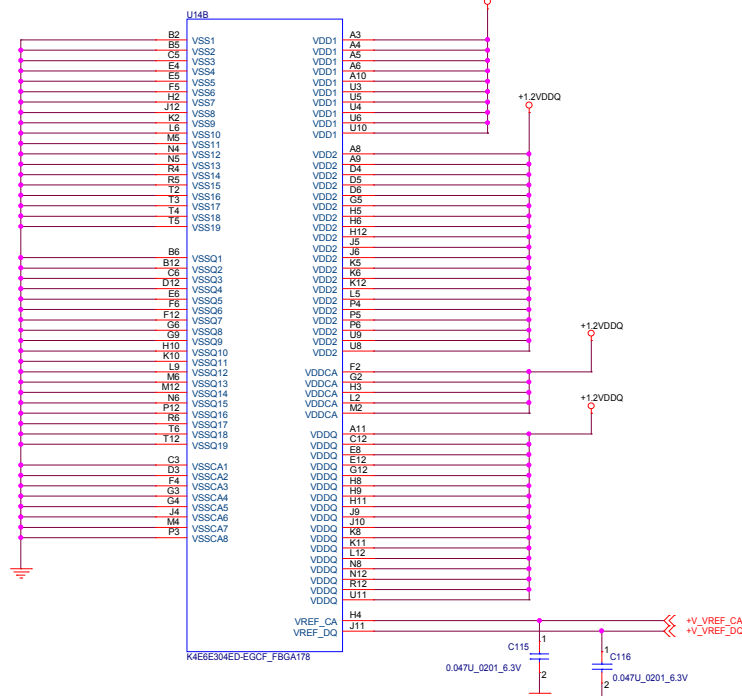
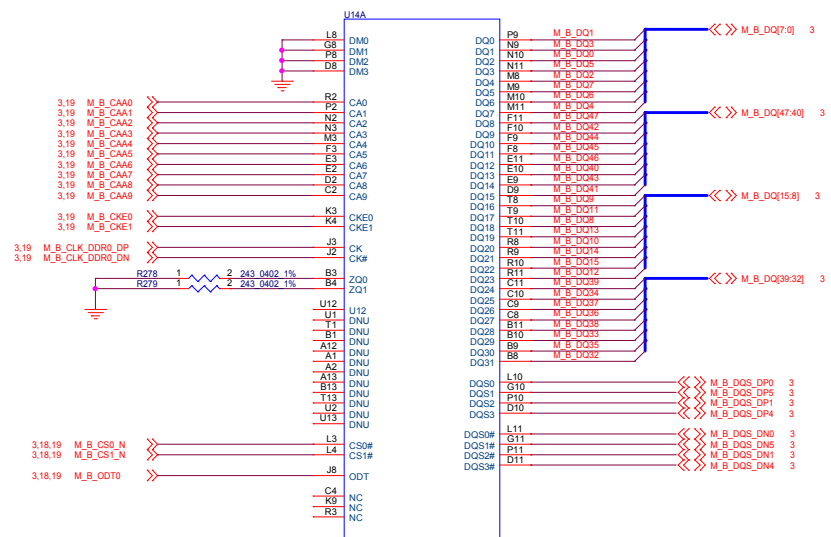

lenovo 联想 LENOVO.CRDN

File AUDIO DSP

Size C	Document Number YOGA4	Rev V1.0
--------	-----------------------	----------

Date: Monday, July 27, 2015 Sheet 18 of 37

PROPERTY NOTE: This document contains information confidential and property to LENOVO PND and shall not be reproduced or transferred to other documents or disclosed to others or used for any purpose other than that for which it was obtained without the expressed written consent of LENOVO PND.

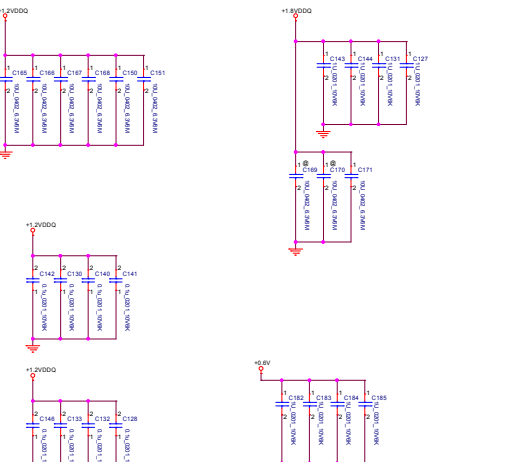
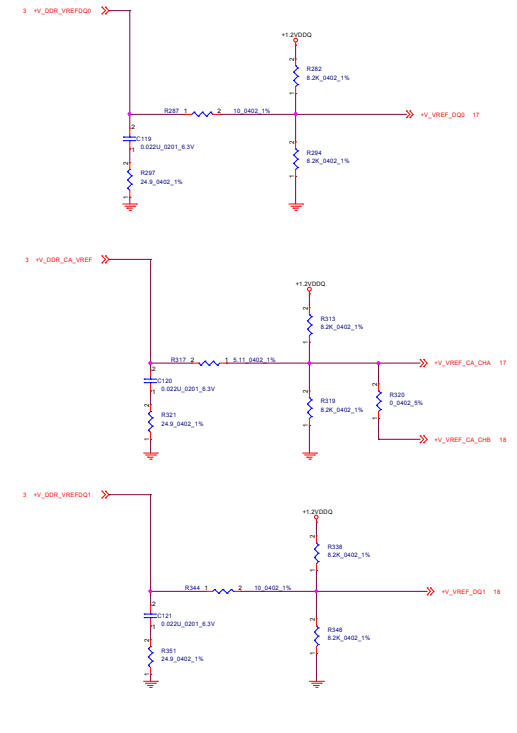
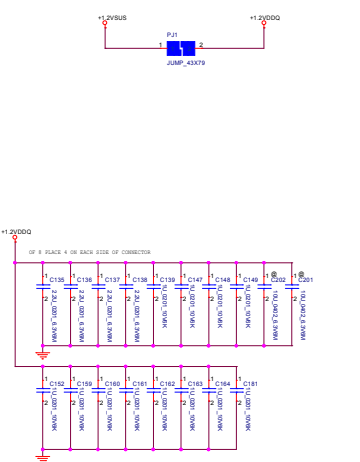
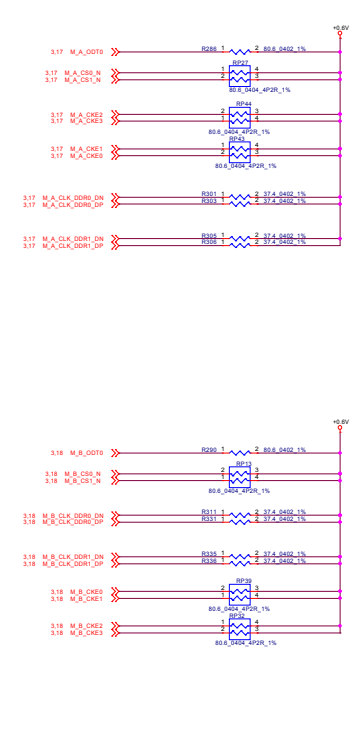
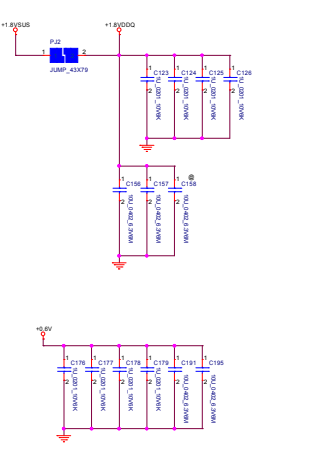
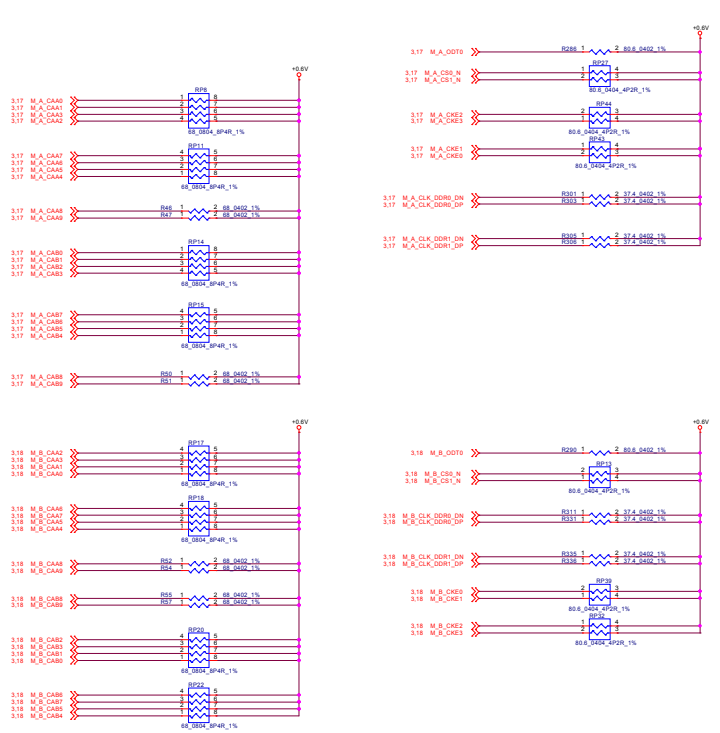

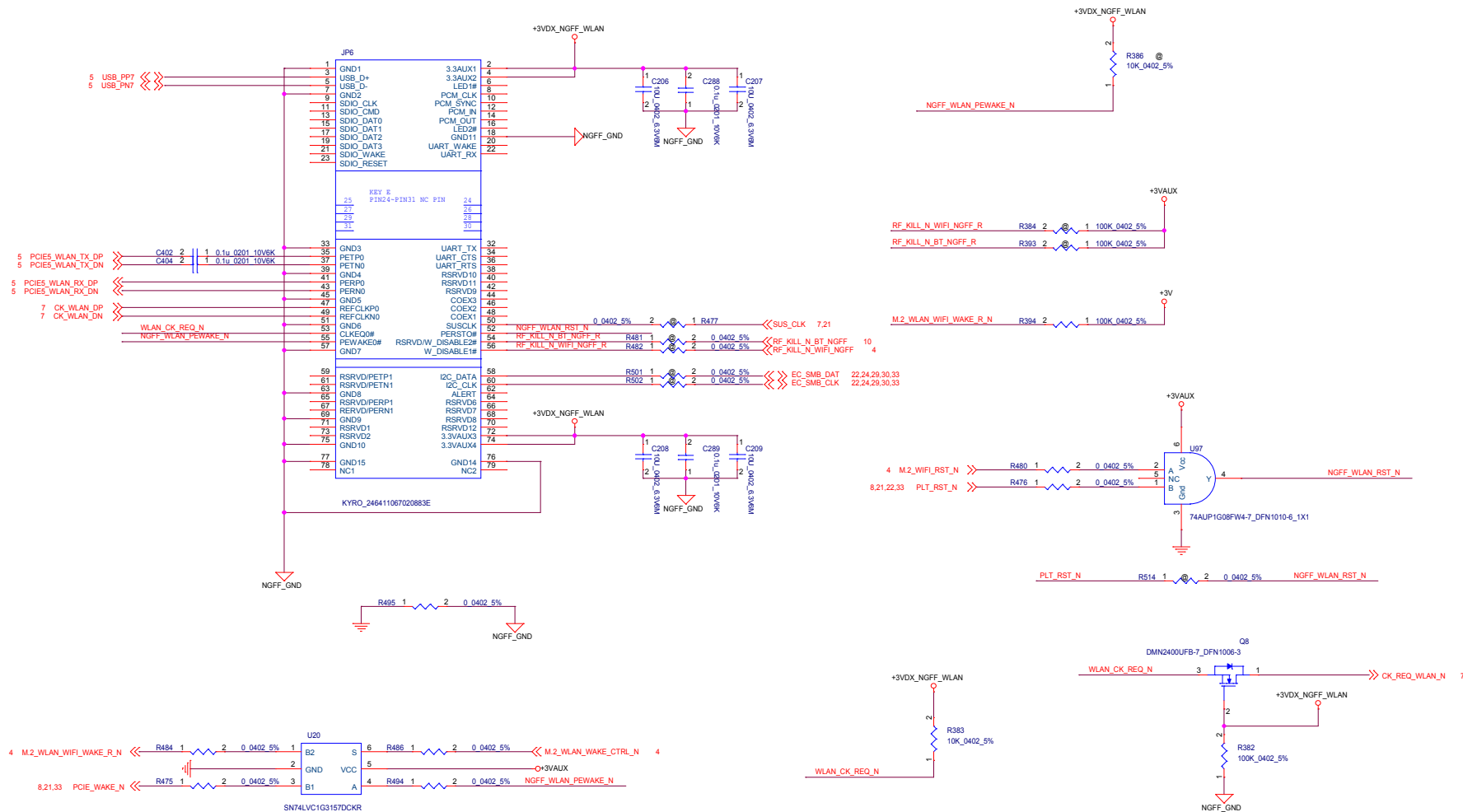

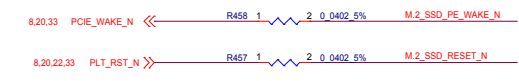
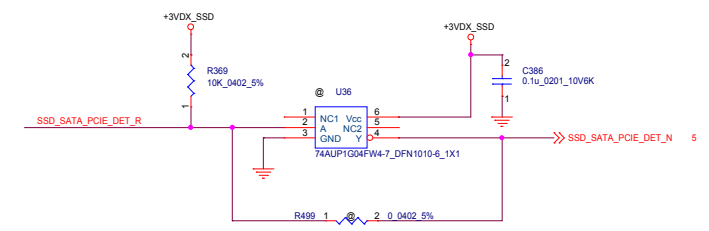
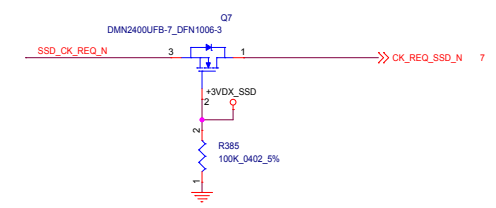
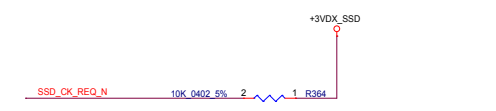
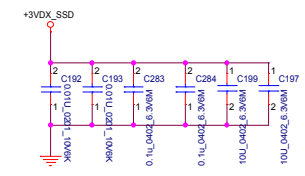
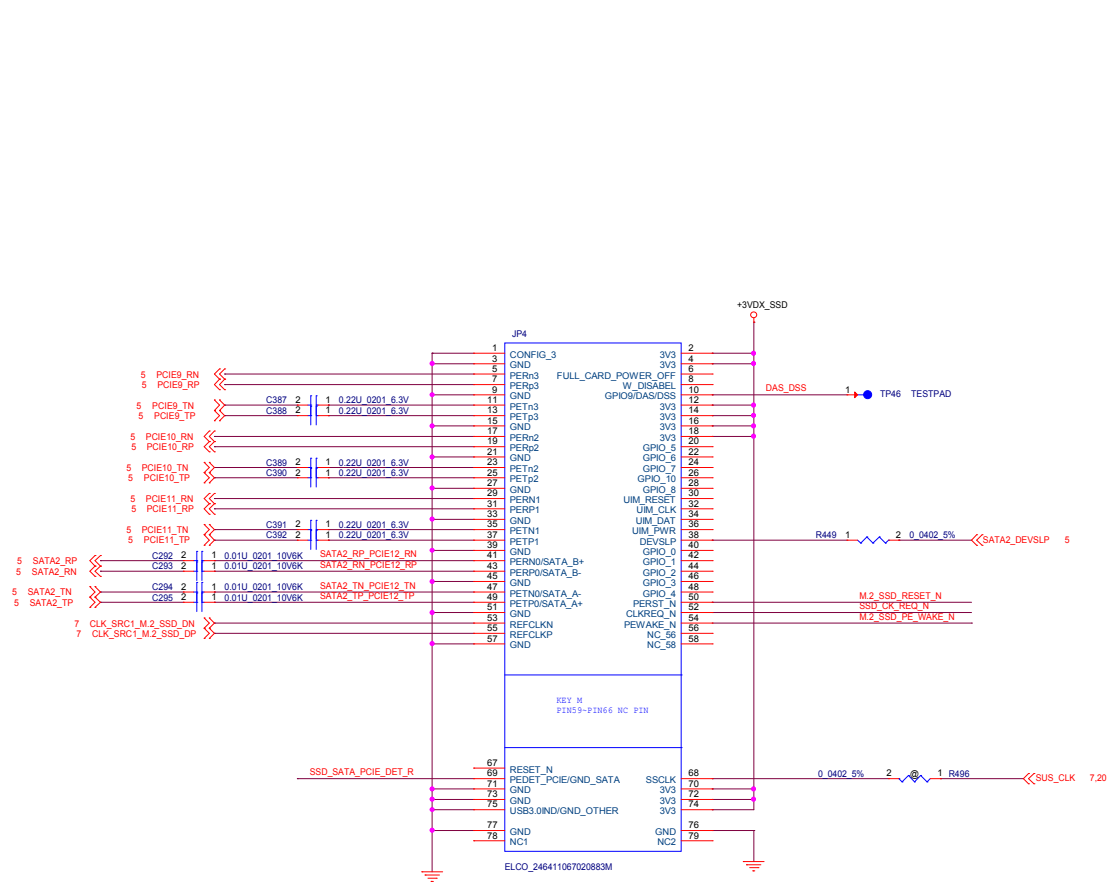

lenovo 联想		LENOVO.CRDN	
Title			
NGFF SSD			
Size	Document Number	Rev	
C	YOGA4	V1.0	
Date:	Monday, July 27, 2015	Sheet	21 of 37
PROPERTY NOTE: This document contains information confidential and property to LENOVO PND and shall not be reproduced or transferred to other documents or disclosed to others or used for any purpose other than that for which it was obtained without the expressed written consent of LENOVO PND.			

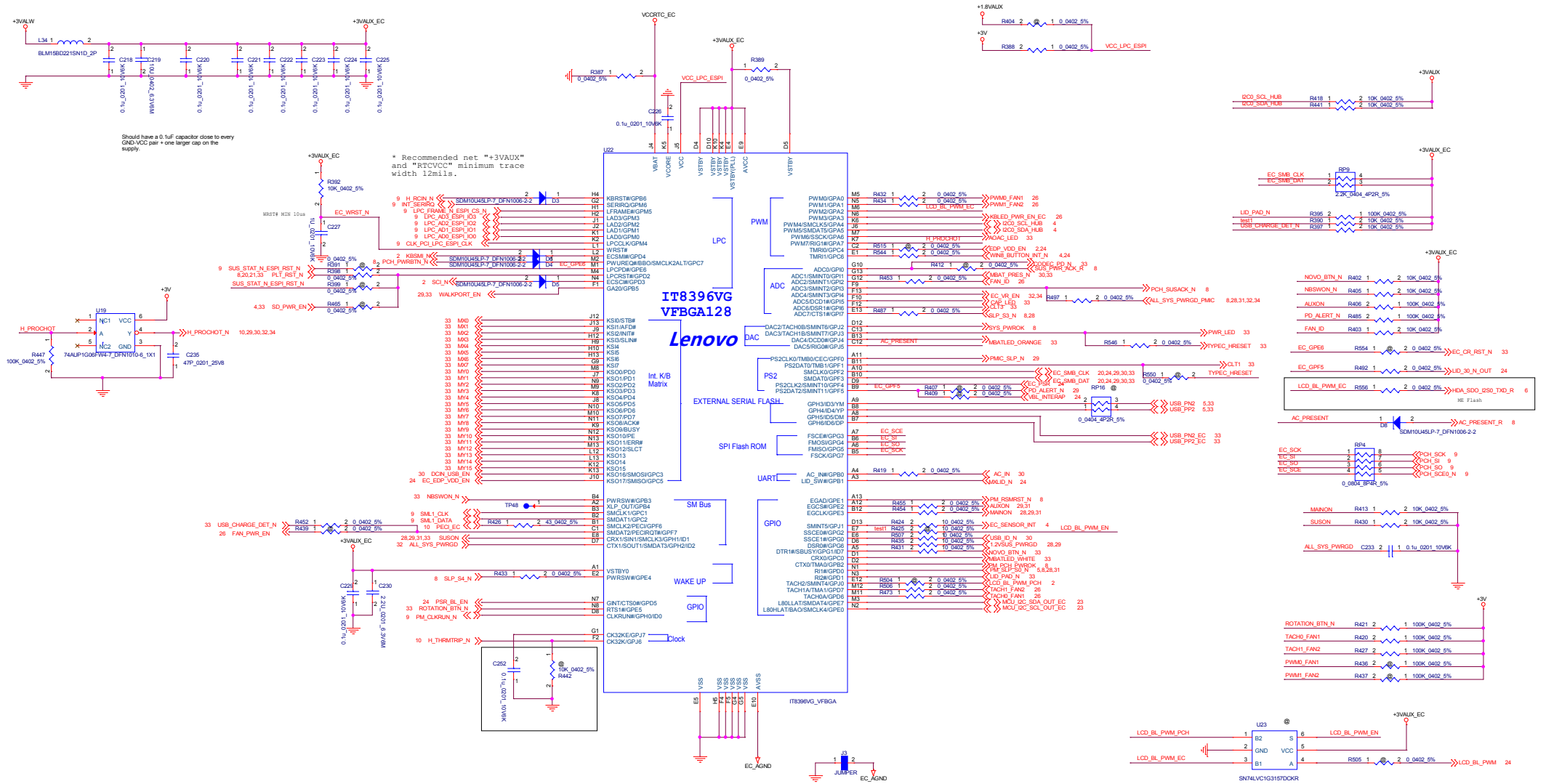

Note 1 : Since all GPIO belong to VSTBY power domain, and there are some special considerations below:
 (1) If it is output to external VCC derived power domain circuit, this signal should be isolated by a diode such as KBRST# and GA20.
 (2) If it is input from external VCC derived power domain circuit, this external circuit must consider not to float the GPIO input.

Note 2 :
 (1) Each input pin should be driven or pulled.
 (2) Each output-drain output pin should be pulled.

lenovo LENOVO.CRDN

Rev: EC BIOS

Docu: YOCM4

Rev: V1.0

Copyright (c) 2015, Lenovo. All rights reserved. This document contains information confidential and proprietary to LENOVO and shall not be reproduced or transferred to other documents or disclosed to others or used for any purpose other than that for which it was prepared without the expressed written consent of LENOVO P&T.

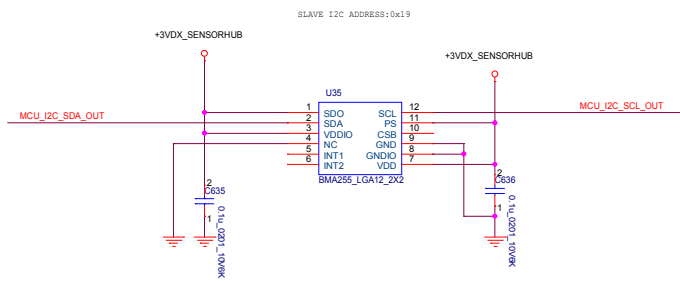
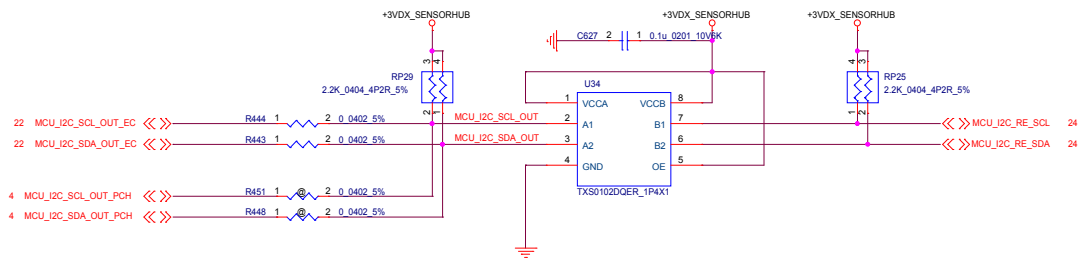

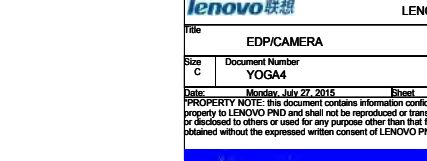
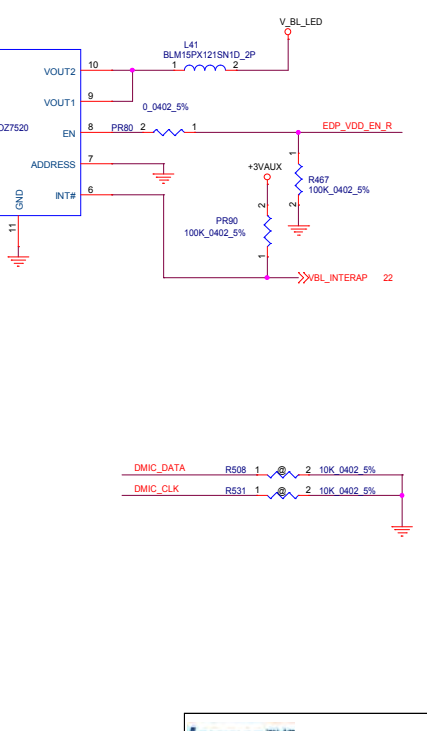
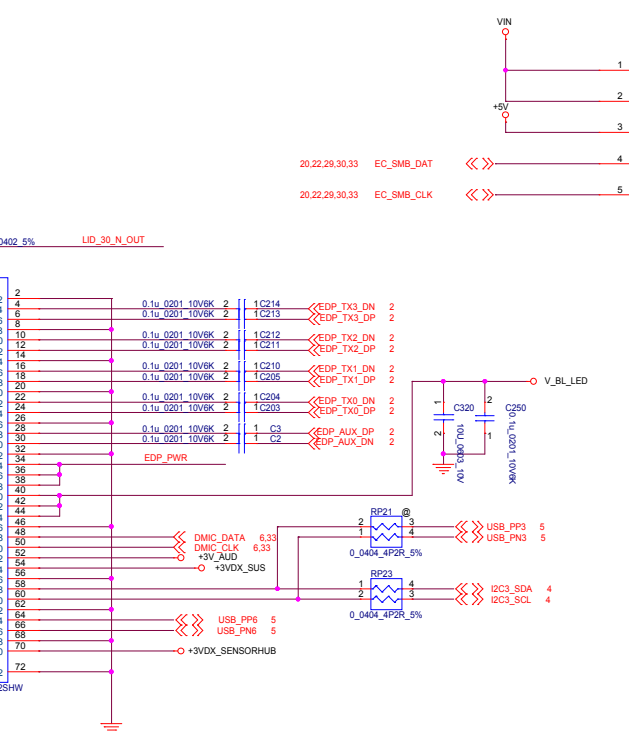
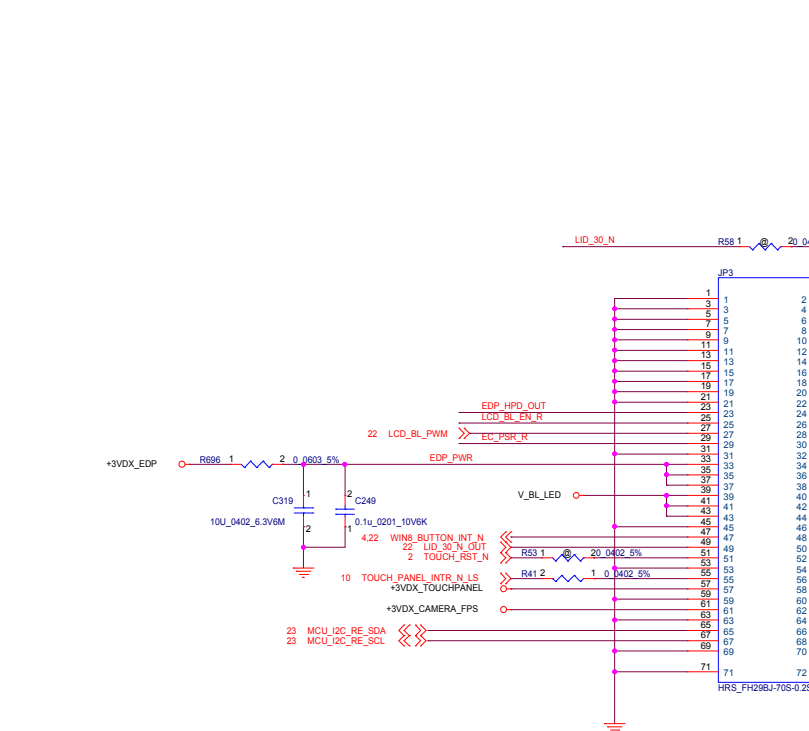
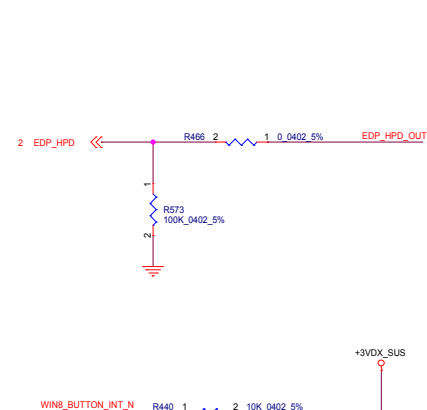
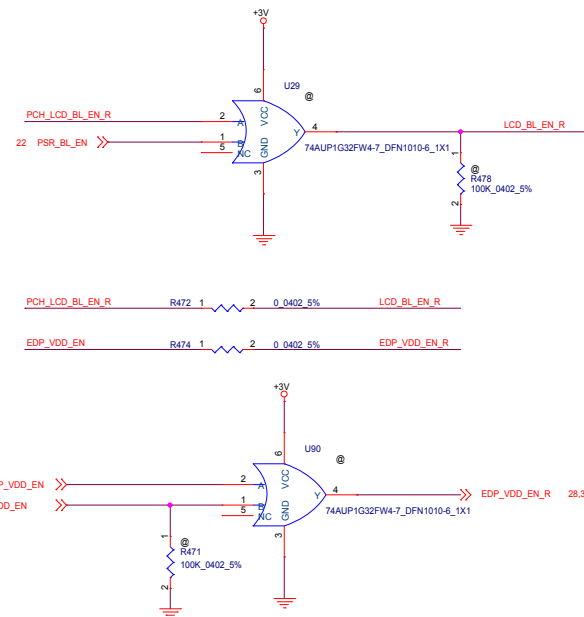
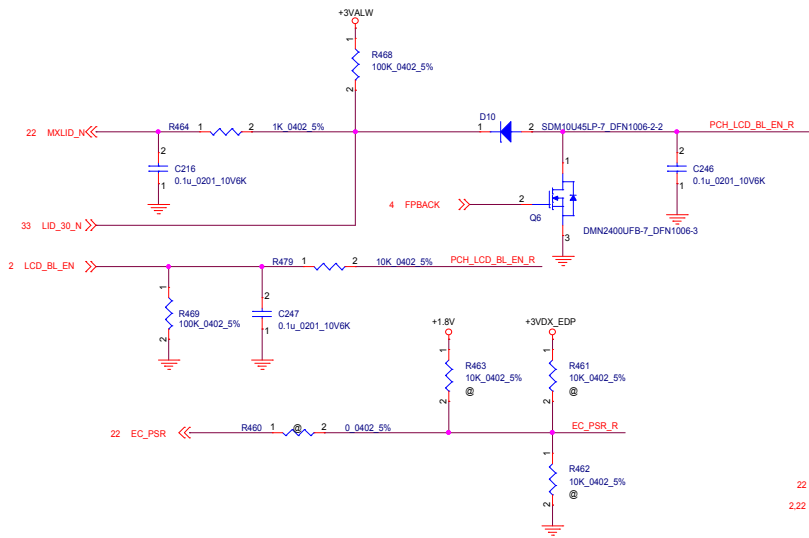

lenovo 联想 LENOVO.CRDN

File EDP/CAMERA

Size C Document Number YOGA4 Rev V1.0

Date: Monday, July 27, 2015 Sheet 24 of 37

PROPERTY NOTE: This document contains information confidential and property to LENOVO PND and shall not be reproduced or transferred to other documents or disclosed to others or used for any purpose other than that for which it was obtained without the expressed written consent of LENOVO PND.

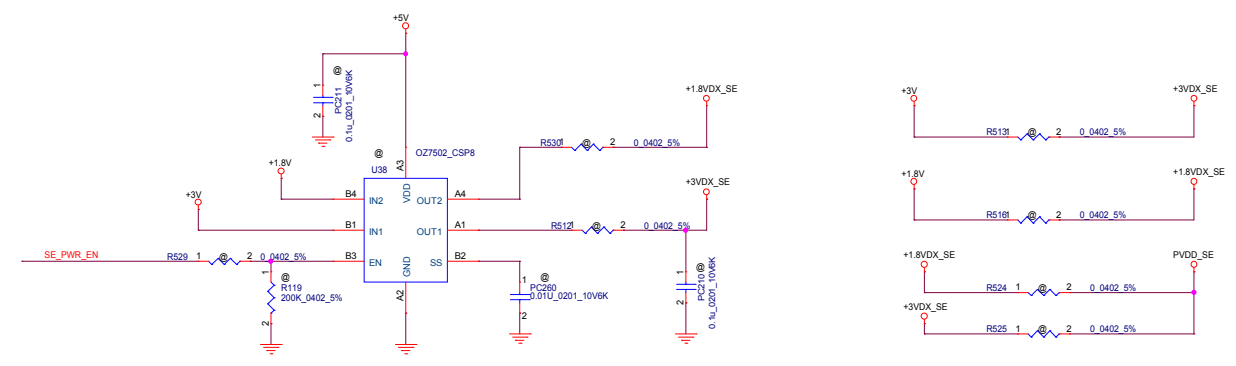
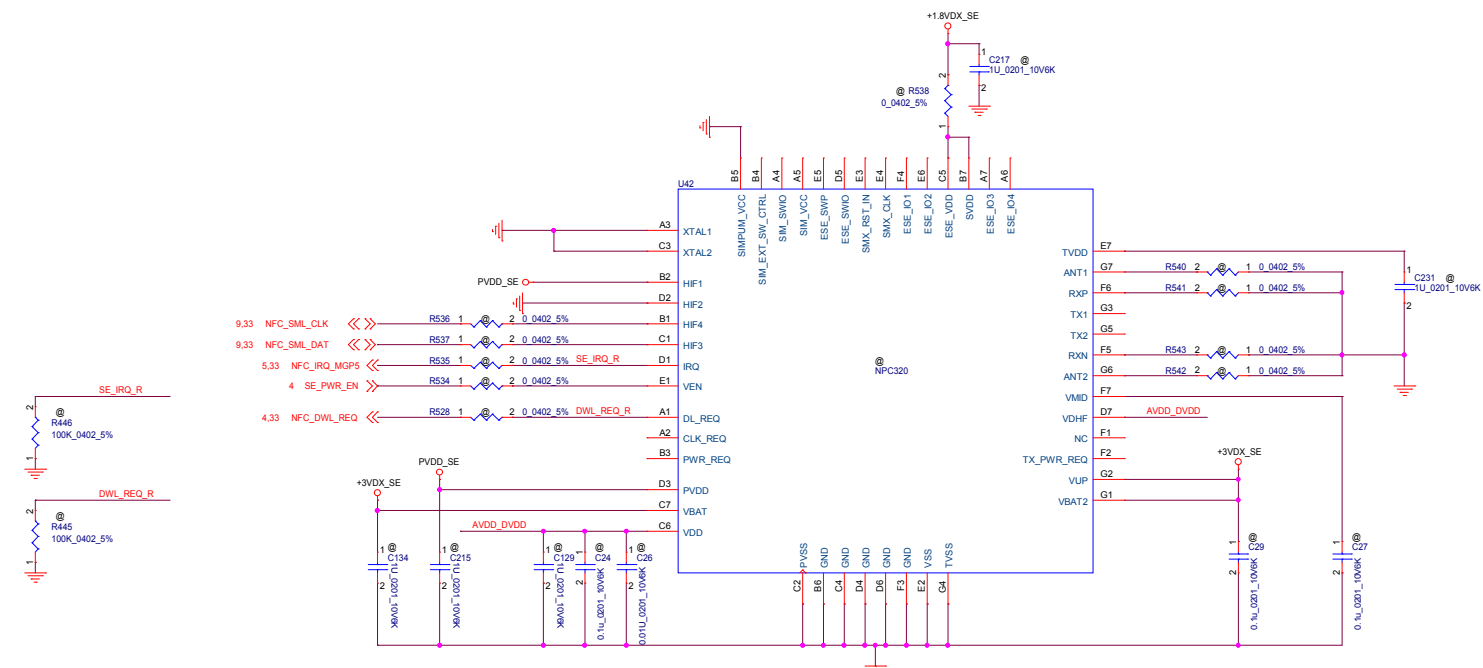

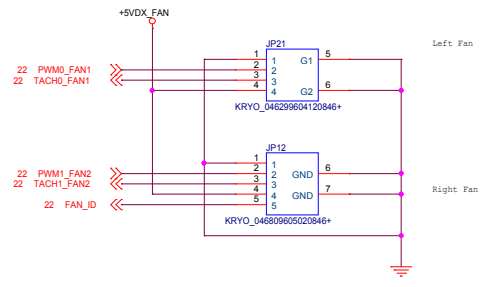
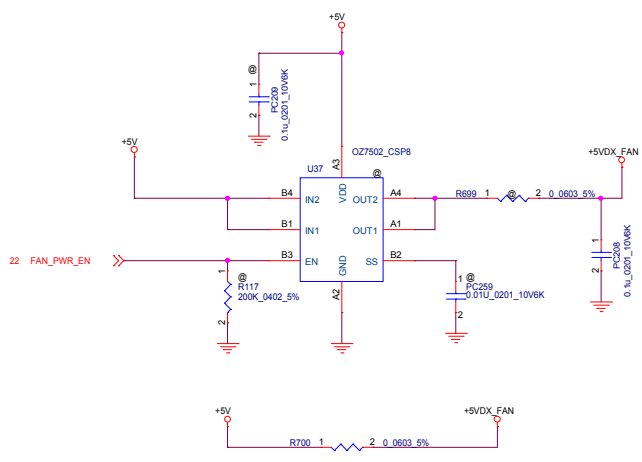
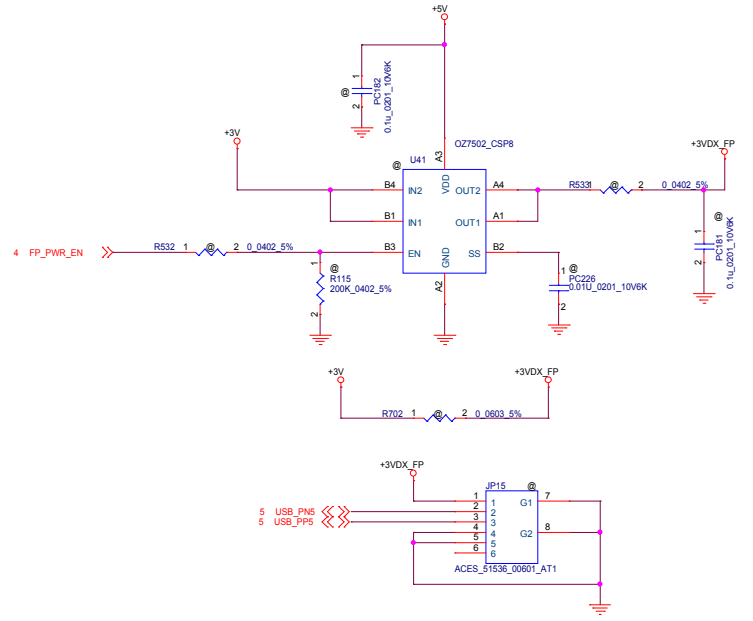
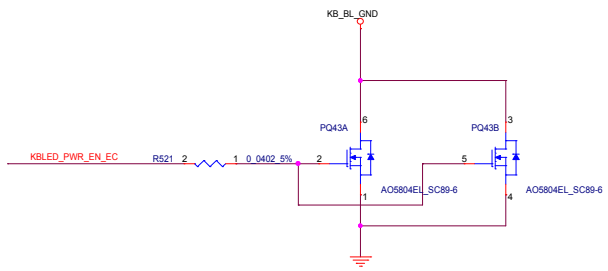
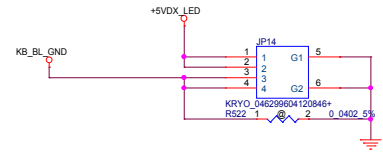
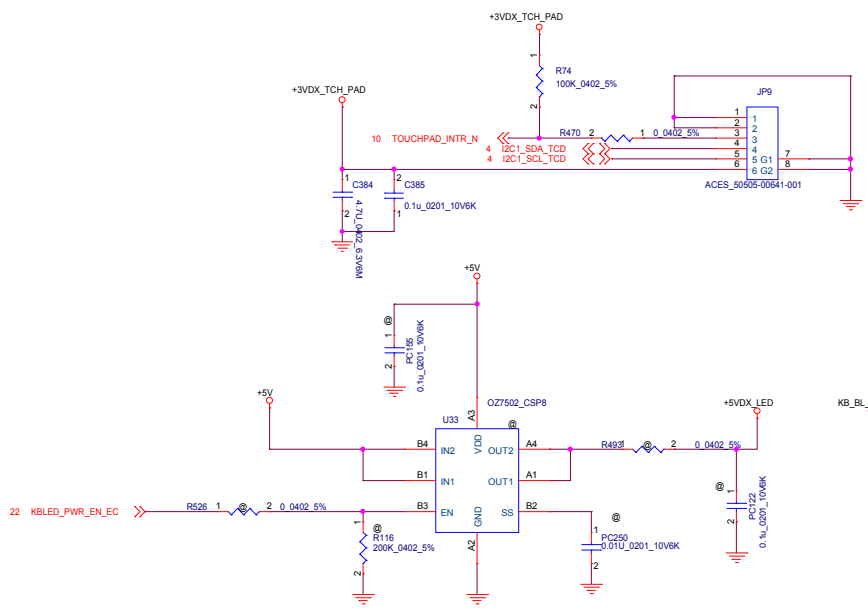

5

4

3

2

1

D

D

C

C

B

B

A

A

		LENOVO.CRDN	
Title PWR LED CONN			
Size C	Document Number YOGA4	Rev V1.0	
Date: Monday, July 27, 2015	Sheet 27	of 37	
<small>PROPERTY NOTE: This document contains information confidential and property to LENOVO PND and shall not be reproduced or transferred to other documents or disclosed to others or used for any purpose other than that for which it was obtained without the expressed written consent of LENOVO PND.*</small>			

5

4

3

2

1

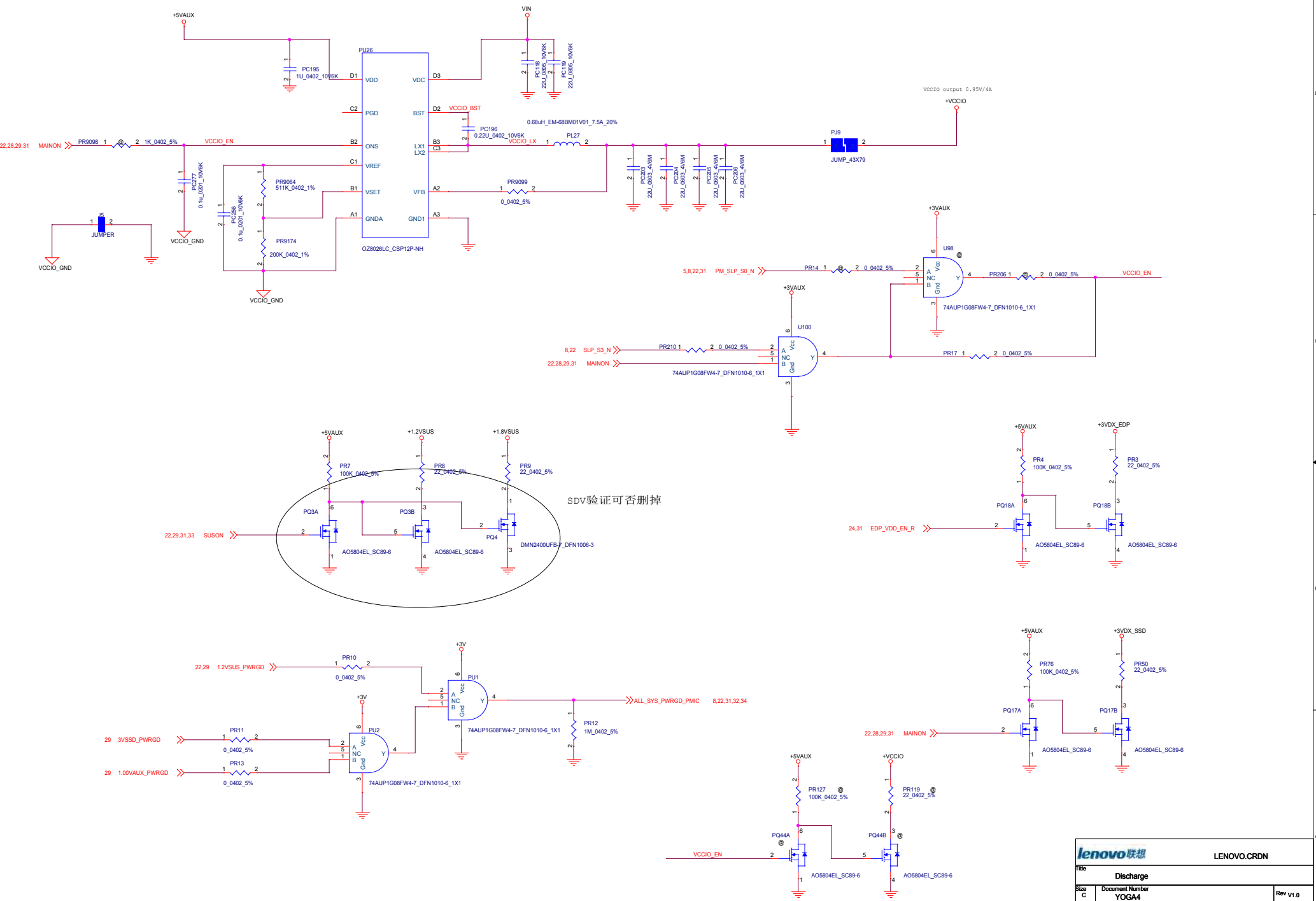

SDV验证可否删掉

lenovo 联想		LENOVO.CRDN
Discharge		
Size	Document Number	Rev
C	YOGA4	V1.0
Date:	Monday, July 27, 2015	Sheet 28 of 37
<small>PROPERTY NOTE: This document contains information confidential and property to LENOVO PND and shall not be reproduced or transferred to other documents or disclosed to others or used for any purpose other than that for which it was obtained without the expressed written consent of LENOVO PND.</small>		

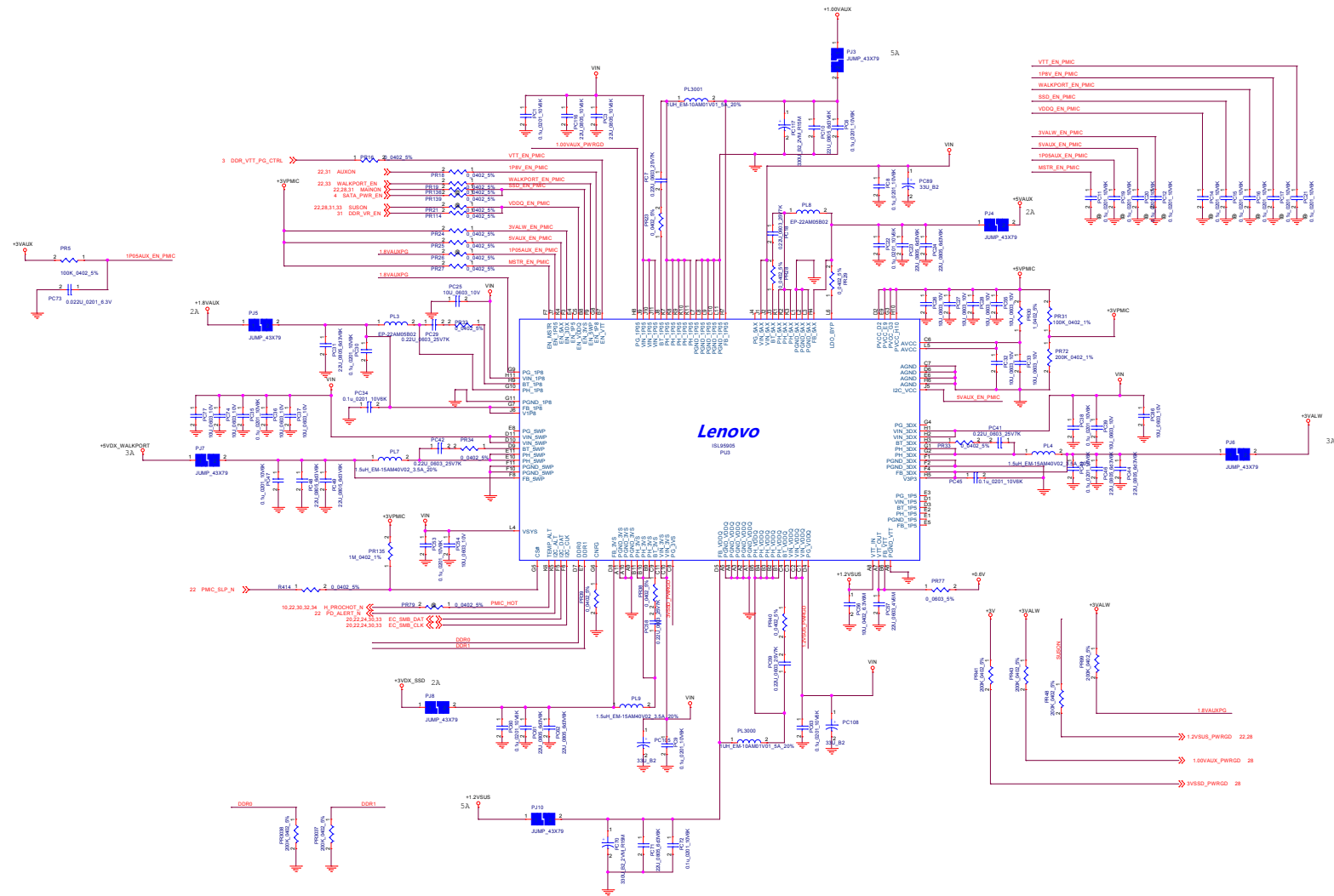

Lenovo

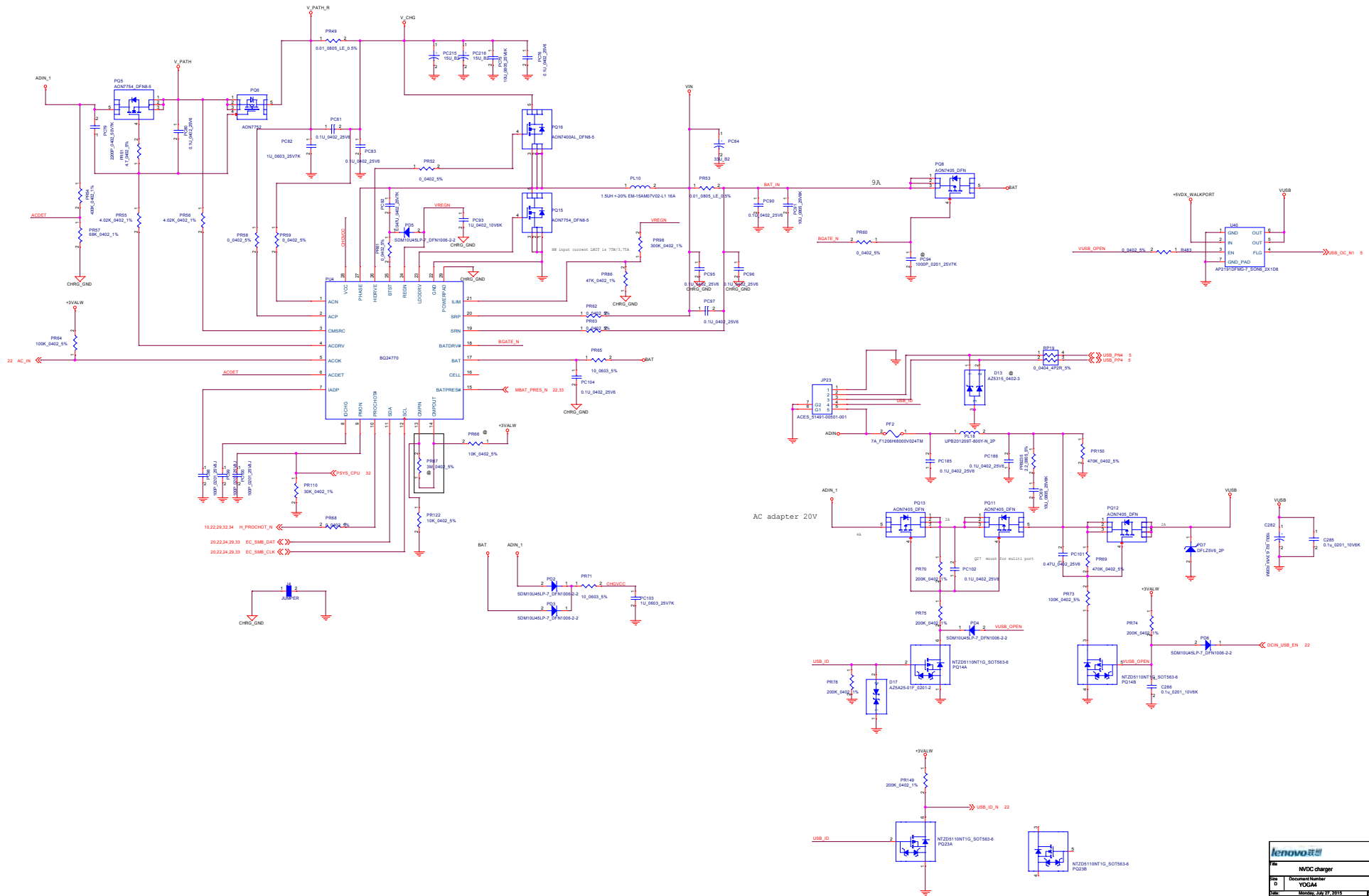

Lenovo		LENOVO ORDN
IN/OC charger		
File	DocuName	Rev
D	YOGA4	v1.0
Date	Created	Sheet
2015/12/27	2015	31
<small>PROPERTY NOTICE: This document contains information confidential and proprietary to LENOVO. This information is intended for internal use only and is not to be reproduced or transmitted to other documents or disclosed to others or used for any purpose other than that for which it was released without the expressed written consent of LENOVO PRC.</small>		

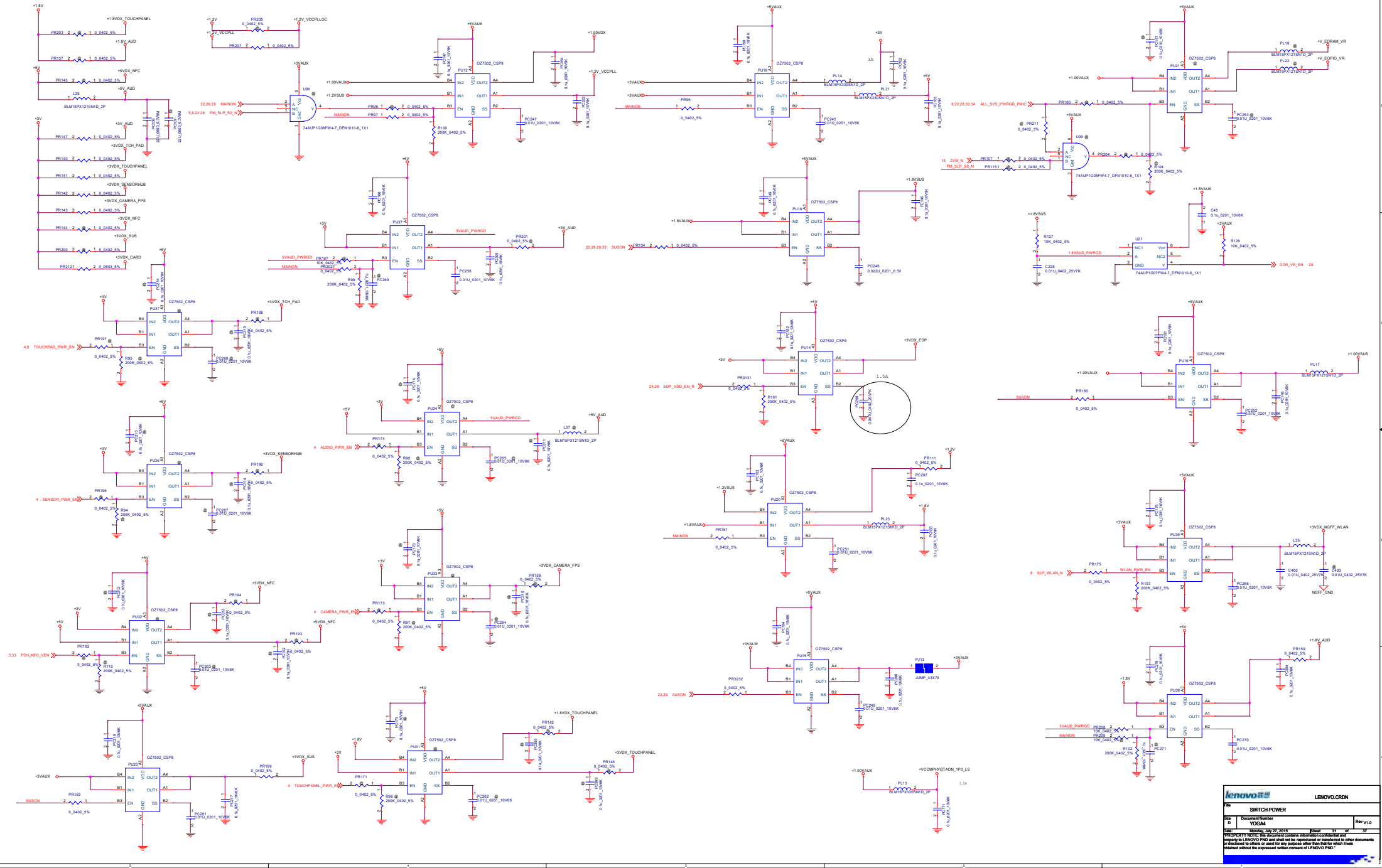

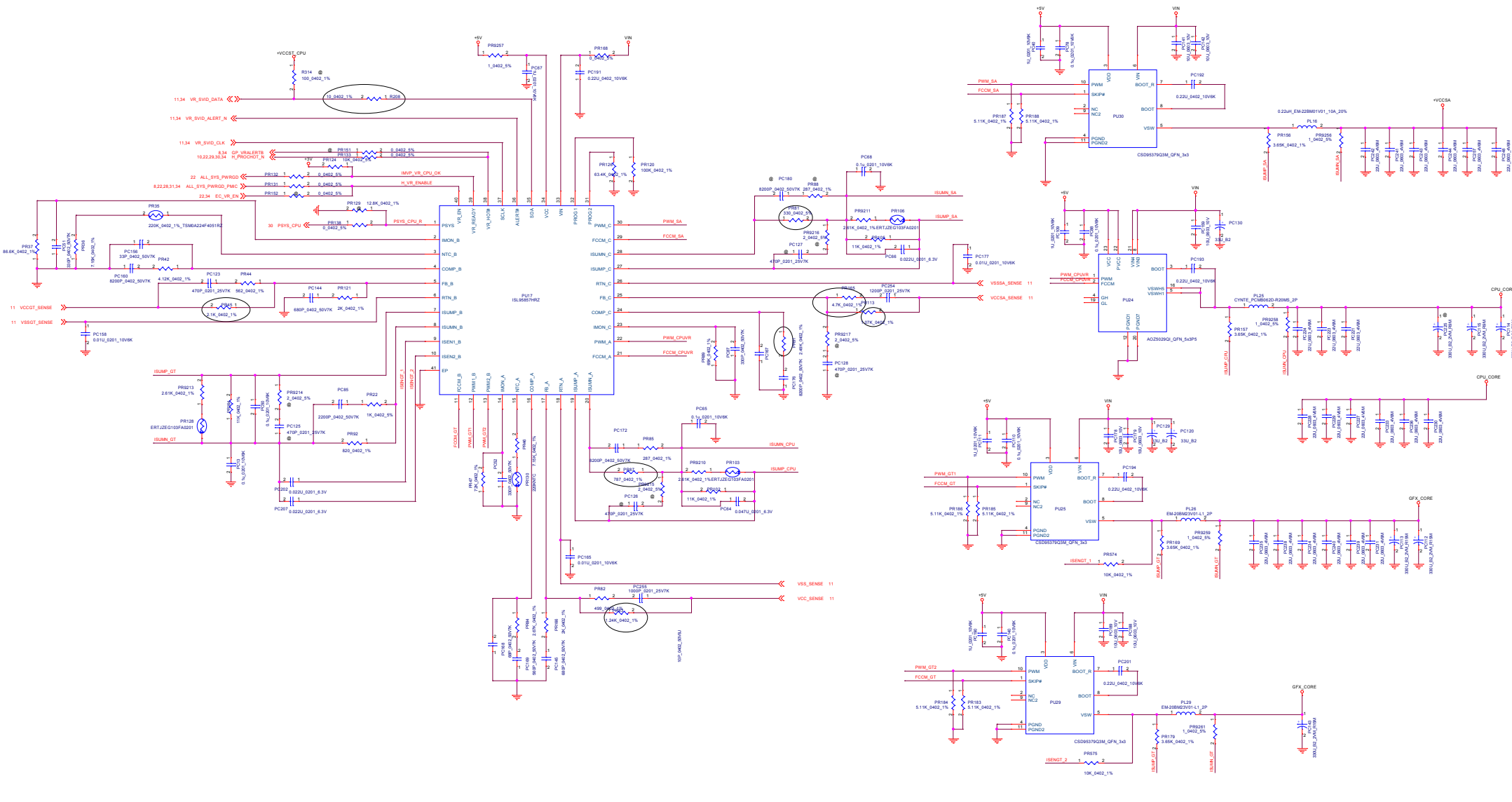

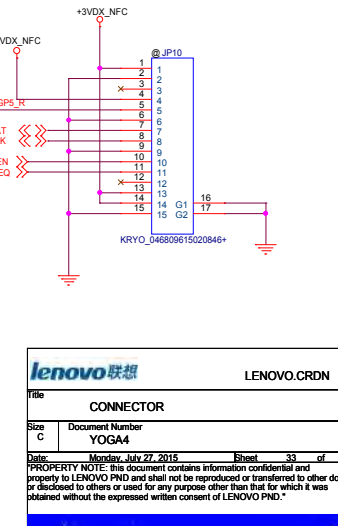
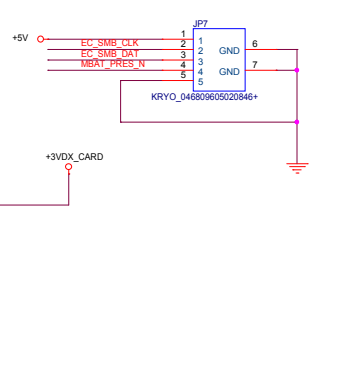
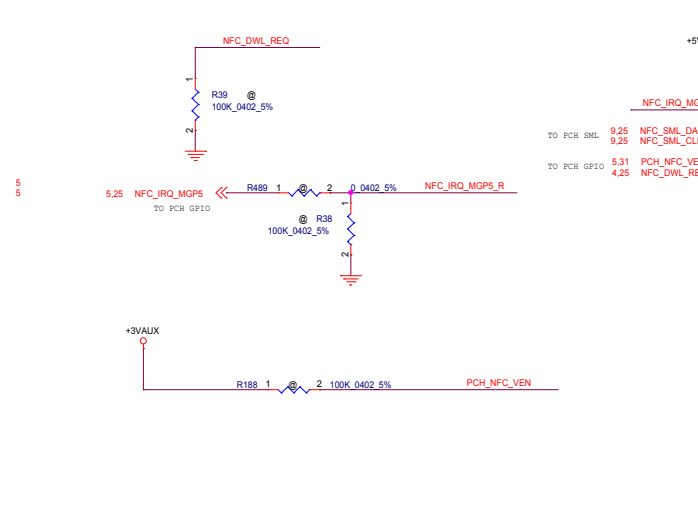
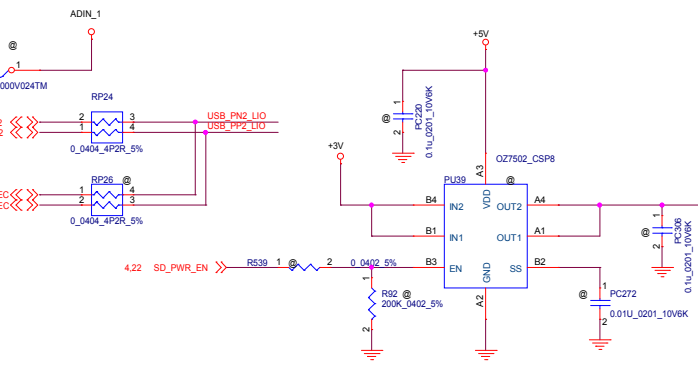
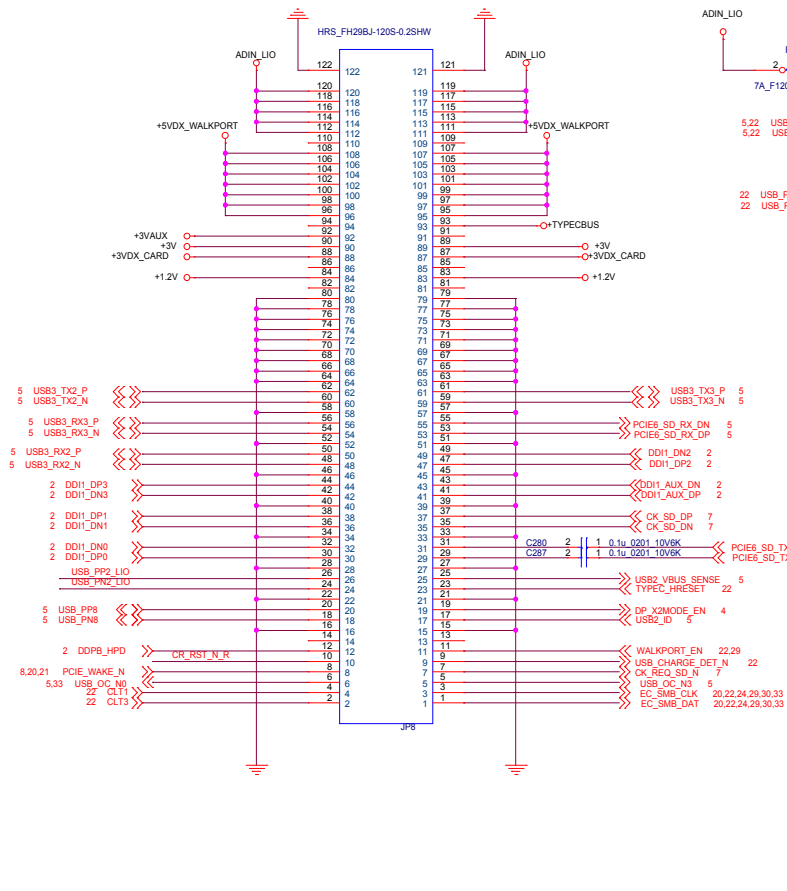
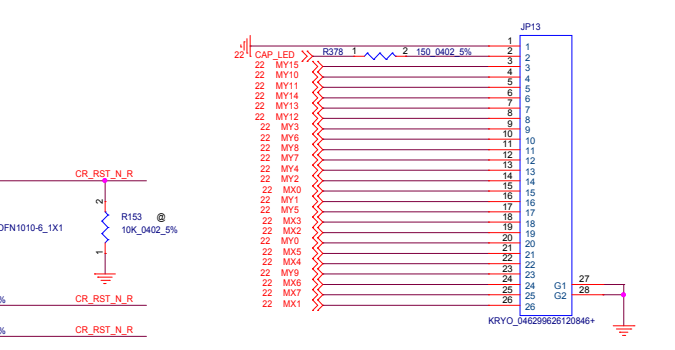
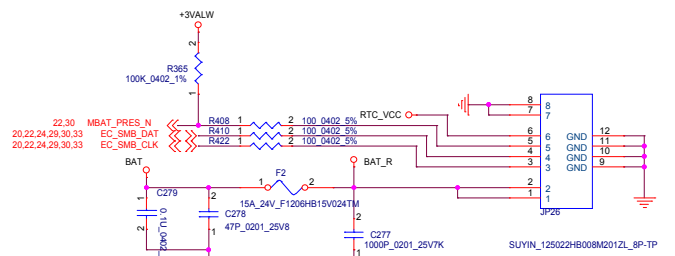
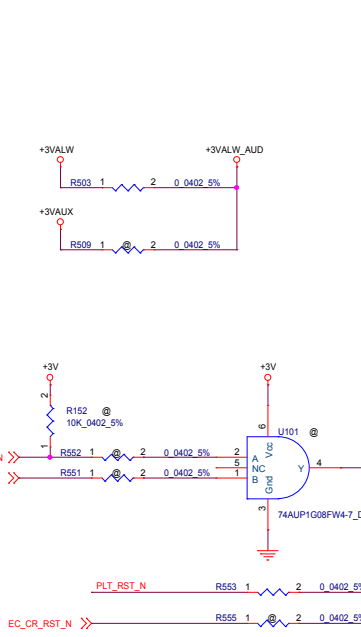
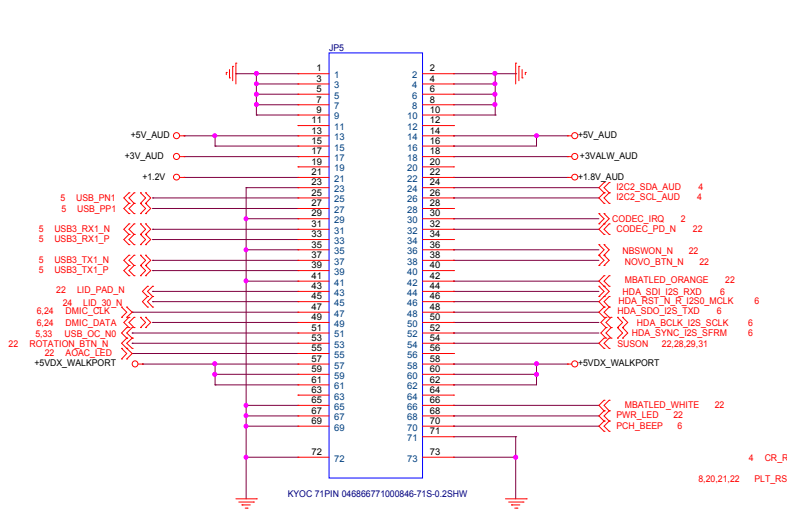

lenovo 联想 LENOVO.CRDN

CONNECTOR

Size	Document Number	Rev
C	YOGA4	v1.0

Date: Monday, July 27, 2015 Sheet 33 of 37

PROPERTY NOTE: This document contains information confidential and property to LENOVO PND and shall not be reproduced or transferred to other documents or disclosed to others or used for any purpose other than that for which it was obtained without the expressed written consent of LENOVO PND.

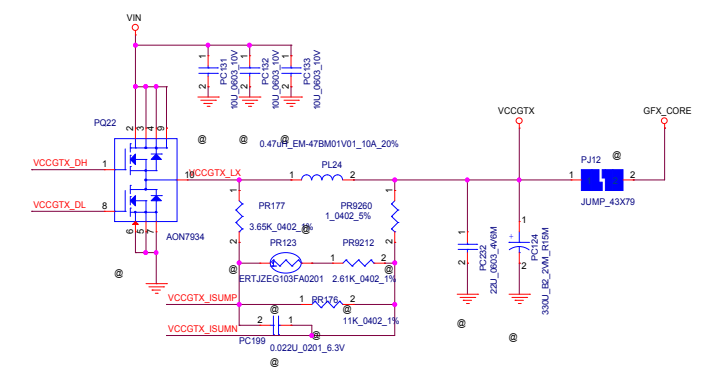
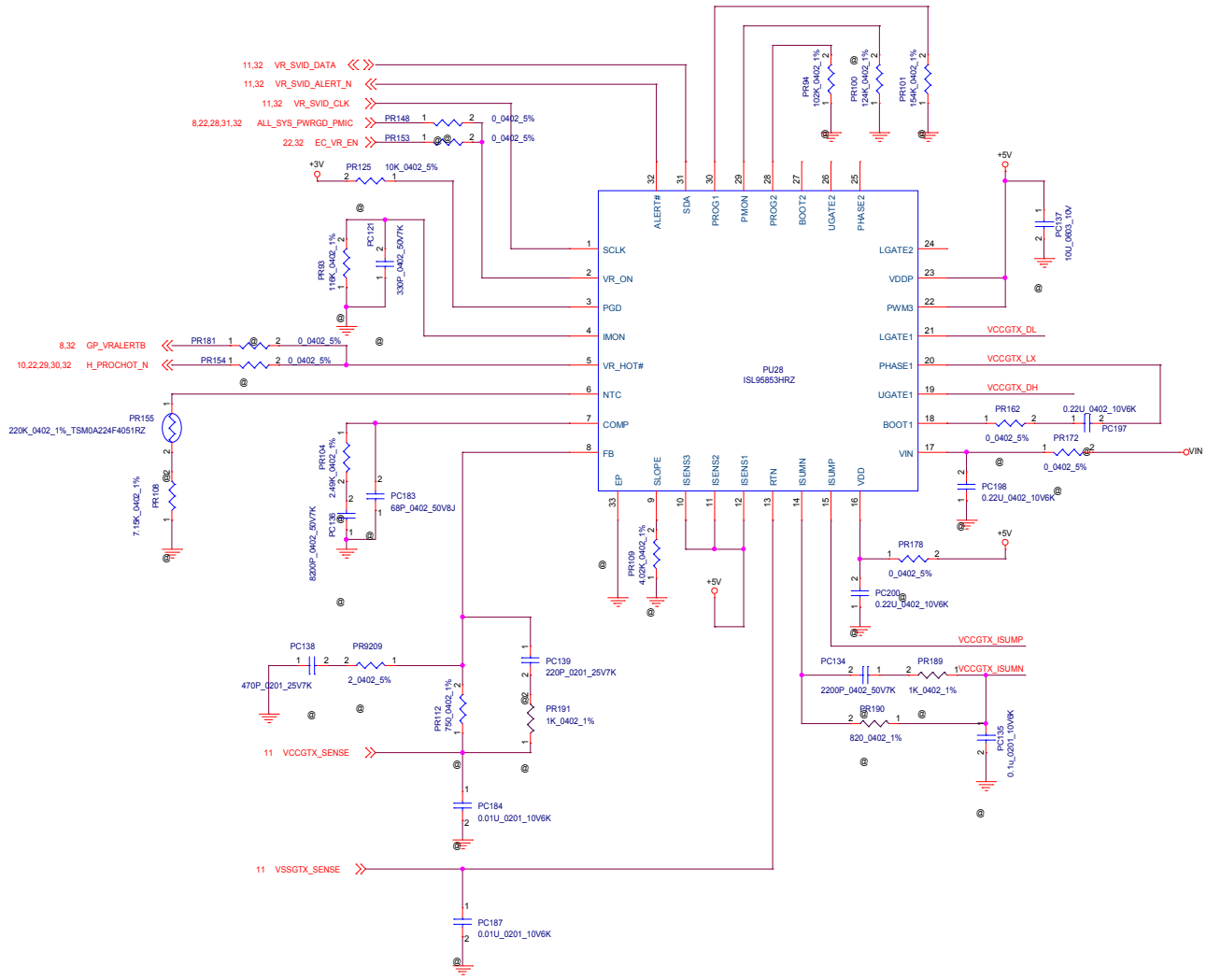

5

4

3

2

1

D

D

C

C

B

B

A

A

		LENOVO.CRDN	
Title			
XXXXX			
Size	Document Number	Rev	
C	YOGA4	V1.0	
Date:	Monday, July 27, 2015	Sheet	35 of 37
<small>PROPERTY NOTE: this document contains information confidential and property to LENOVO PND and shall not be reproduced or transferred to other documents or disclosed to others or used for any purpose other than that for which it was obtained without the expressed written consent of LENOVO PND.*</small>			

5

4

3

2

1

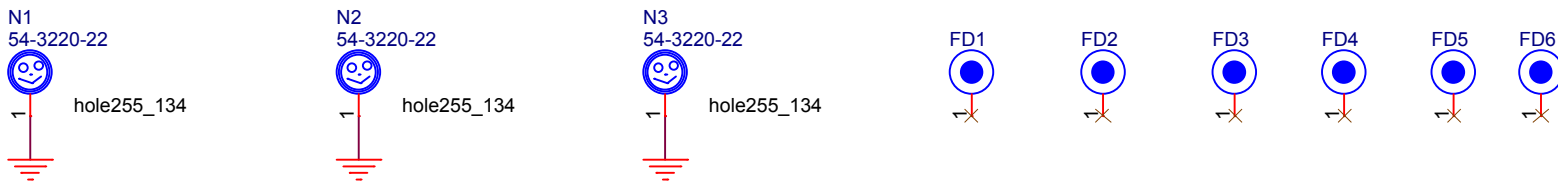
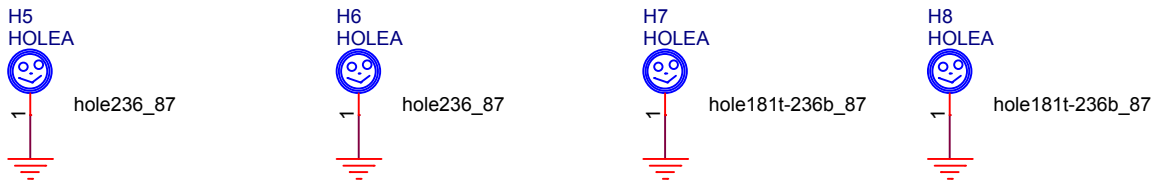
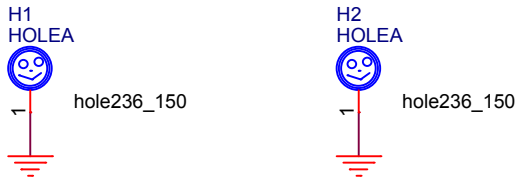
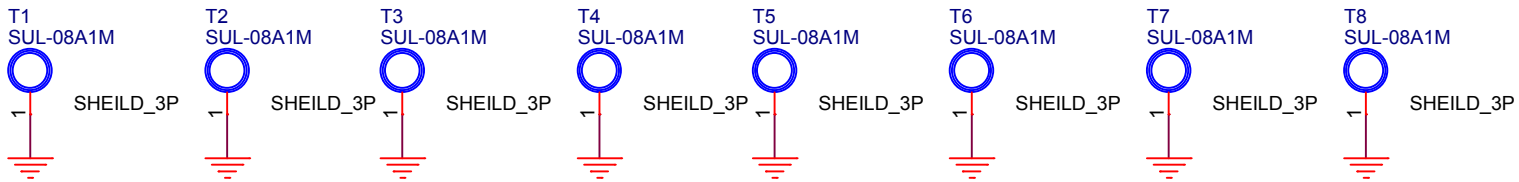

		LENOVO.CRDN
Title MOUNTING HOLE/EMI		
Size A	Document Number YOGA4	Rev v1.0
Date: Monday, July 27, 2015		Sheet 36 of 37
"PROPERTY NOTE: this document contains information confidential and property to LENOVO PND and shall not be reproduced or transferred to other documents or disclosed to others or used for any purpose other than that for which it was obtained without the expressed written consent of LENOVO PND."		

