

LCFC Confidential

Miray-KBL M/B Schematics Document

INTEL KABYLAKE Mobile ULT Platform
INTEL KBL Y-series CPU + LPDDR3 Memory

2016-06-21

REV: 1.0

Security Classification	LC Future Center Secret Data			Title	
Issued Date	2015/11/09	Deciphered Date	2016/06/27	Cover Page	
<small>THIS SHEET OF ENGINEERING DRAWING IS THE PROPRIETARY PROPERTY OF LC FUTURE CENTER, AND CONTAINS CONFIDENTIAL AND TRADE SECRET INFORMATION. THIS SHEET MAY NOT BE TRANSFERRED FROM THE CUSTODY OF THE COMPETENT DIVISION OF R&D DEPARTMENT EXCEPT AS AUTHORIZED BY LC FUTURE CENTER. NEITHER THIS SHEET NOR THE INFORMATION IT CONTAINS MAY BE USED BY OR DISCLOSED TO ANY THIRD PARTY WITHOUT PRIOR WRITTEN CONSENT OF LC FUTURE CENTER.</small>					
Size	Document Number			Miray-K	Rev 1.0
Date:	Thursday, June 23, 2016			Sheet	1 of 38

LCFC-Miary Block diagram

Vinafix.com

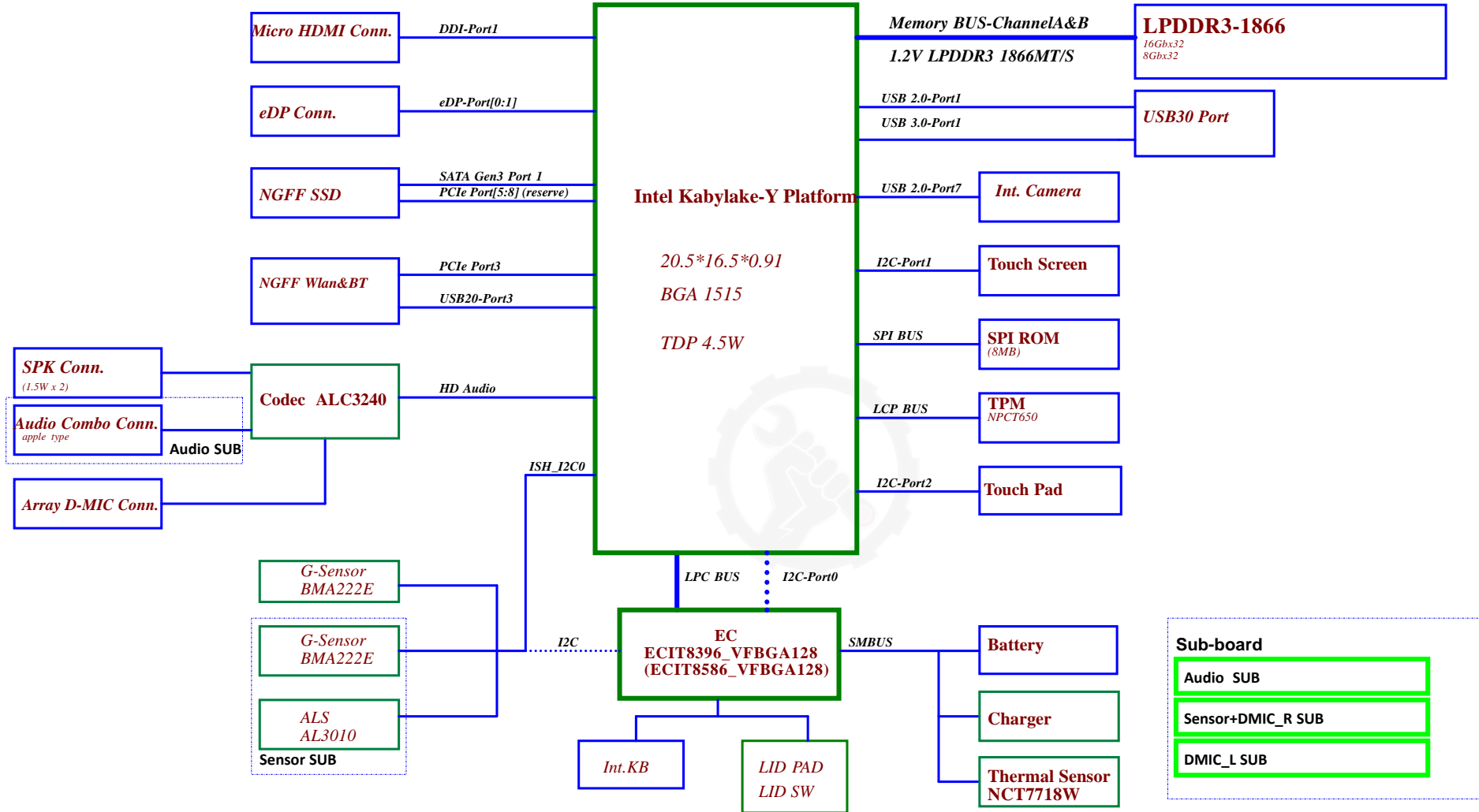

Voltage Rails (O --> Means ON , X --> Means OFF)

Power Plane	B+	+3VALW	+5VALW	+1.0VALW	+1.8VALW	+3VALW_PCH	+DDR_1.2V	+DDR_1.8V	+5VS	+3VS	+1.8VS	+DDR_0.6VS	+CPU_CORE	+CPU_VCCIO	+CPU_VCCGT	+CPU_VCCSA
State	+3VL	+5VLP	+CPU_VCCPRIM													
S0	O	O	O	O	O	O	O	O	O	O	O	O	O	O	O	O
S3	O	O	O	O	O	O	O	O	X	X	X	X	X	X	X	X
DS3	O	O	O	X	O	O	O	O	X	X	X	X	X	X	X	X
S5 S4/AC Only	O	O	O	O	O	O	X	O	X	X	X	X	X	X	X	X
S5 S4 Battery only	O	X	X	X	X	X	X	X	X	X	X	X	X	X	X	X
S5 S4 AC & Battery don't exist	X	X	X	X	X	X	X	X	X	X	X	X	X	X	X	X

STATE	SIGNAL	SLP_S1#	SLP_S3#	SLP_S4#	+VALW	+VALW_PCH	+V	+VS	ClOCK
Full ON	HIGH	HIGH	HIGH	HIGH	ON	ON	ON	ON	ON
S1(Power On Suspend)	LOW	HIGH	HIGH	HIGH	ON	ON	ON	ON	LOW
S3 (Suspend to RAM)	LOW	LOW	HIGH	HIGH	ON	ON	ON	OFF	OFF
DS3 (Suspend to RAM)	LOW	LOW	HIGH	HIGH	ON	LOW	ON	OFF	OFF
S4 (Suspend to Disk)	LOW	LOW	LOW	LOW	ON	ON	OFF	OFF	OFF
S5 (Soft OFF)	LOW	LOW	LOW	LOW	ON	ON	OFF	OFF	OFF

SMBUS Control Table

	SOURCE	Sensor	ALS	BATT	Thermal Sensor	charger	EC
EC_SMB_CLK1	IT8586						
EC_SMB_DAT1	+3VALW_EC	X	X	V	X	V	X
EC_SMB_CLK3	IT8586	V	V	X	X	X	X
EC_SMB_DAT3	+3VS	+3VS	+3VS	X	X	X	X
EC_SMB_CLK0	IT8586						
EC_SMB_DAT0	+3VS	X	X	X	V	X	X
		+3VS			+3VS		
EC_SMB_CLK4	PCH						V
EC_SMB_DAT4	+3VS	X	X	X	X	X	+3VS

SM Bus address

Device	address
Battery	0001_011X b
Charger	
Sensor	
ALS	
Thermal Sensor	1001_100xb
EC	
PCH	
EC4	

PCIe PORT LIST

Port	Device
1	
2	
3	WLAN
4	
5--8	Reserve PCIe SSD
8	SATA SSD

USB Port Table

	USB20	USB30
1	USB	USB
2		
3		
4	BT	
5		
6		
7	Camera	
8		
9		

BOM Structure Table

BOM Structure		BOM Structure	
TI@	TI MIPI camera mount	MIRROR@	EC Mirror-code enable
TPM@	TPM module	UNMIRROR@	EC Mirror-code disable
DEBUG@	DEBUG CARD Part	DA8@	PCB
ME@	ME part(connector, hole)	UPI@	UPI MIPI camera mount
RF@	RF request		
EMC@	EMC request		
CD@	COST DOWN Part		
REV@	RESERVER Part		

Board ID Table

Board ID	Description	PCB Revision

BOM Configuration Table

SKU	Description	BOM Config
SKU1		
SKU2		

X76&VGA Configuration Table

SKU	Description	BOM Config

PCB And LOGO Config

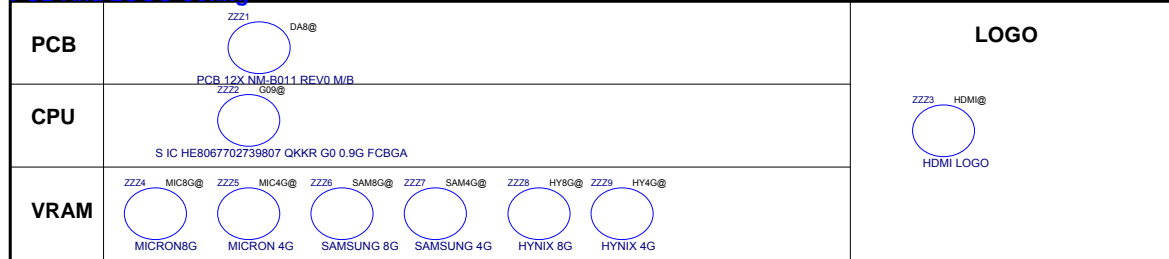

Security Classification	LC Future Center Secret Data		Title
Issued Date	2015/11/09	Deciphered Date	2016/06/27
<small>THIS SHEET OF ENGINEERING DRAWING IS THE PROPRIETARY PROPERTY OF LC FUTURE CENTER, AND CONTAINS CONFIDENTIAL AND TRADE SECRET INFORMATION. THIS SHEET MAY NOT BE TRANSFERRED FROM THE CUSTODY OF THE COMPETENT DIVISION OF R&D DEPARTMENT EXCEPT AS AUTHORIZED BY LC FUTURE CENTER. NEITHER THIS SHEET NOR THE INFORMATION IT CONTAINS MAY BE USED BY OR DISCLOSED TO ANY THIRD PARTY WITHOUT PRIOR WRITTEN CONSENT OF LC FUTURE CENTER.</small>			Notes List Size Document Number Miray-K Date: Thursday, June 23, 2016 Sheet 3 of 38

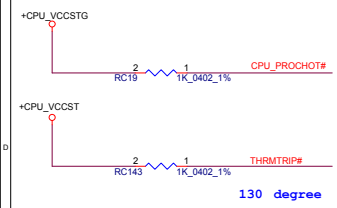

TPM_ID1	Description
0	NO physical TPM
1	physical TPM

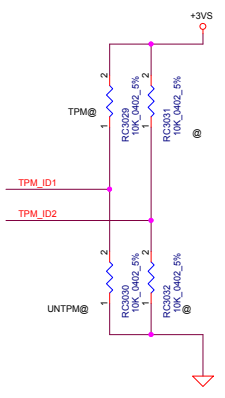

0901 add

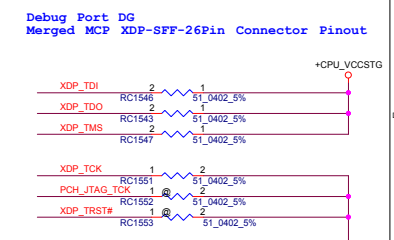
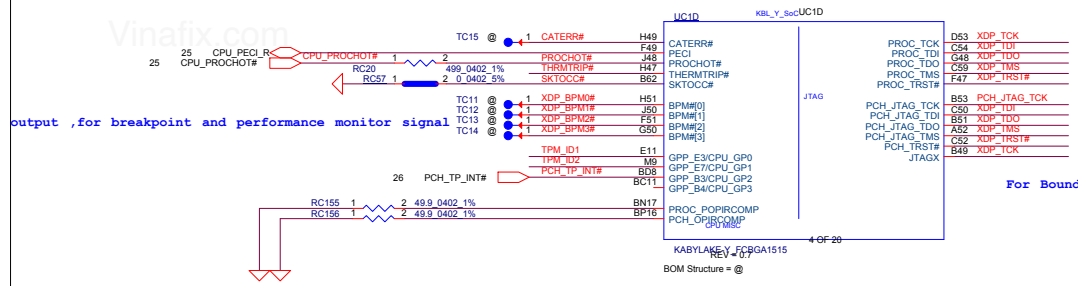

Non-interleave ballmap

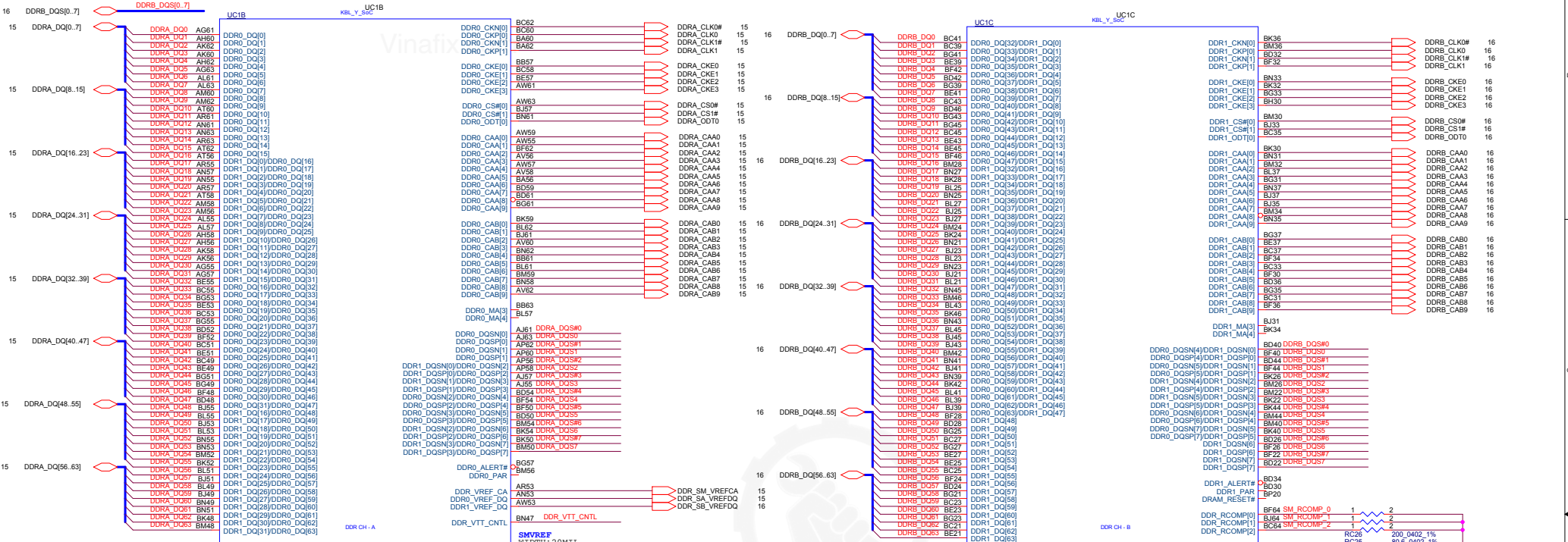

KABYLAK EFGA1515 2 OF 20 BOM Structure = @
 KABYLAK EFGA1515 3 OF 20 BOM Structure = @

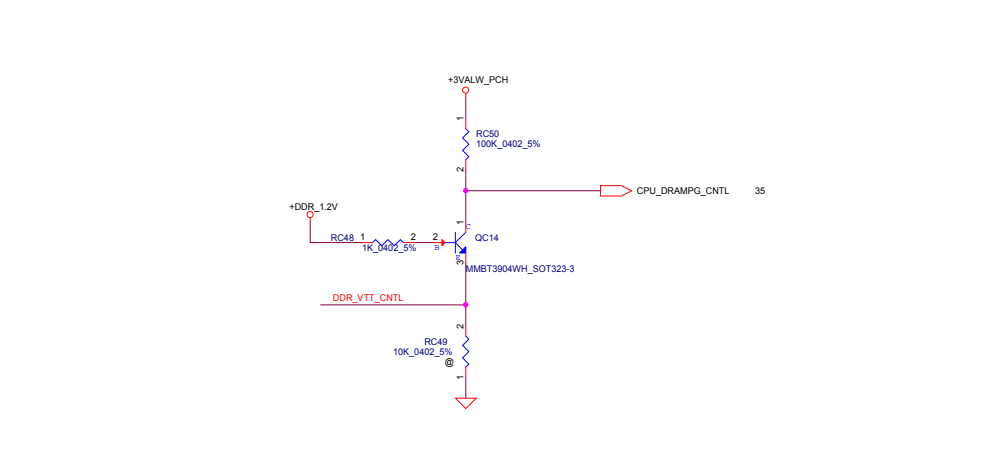

Need to check the resistor value

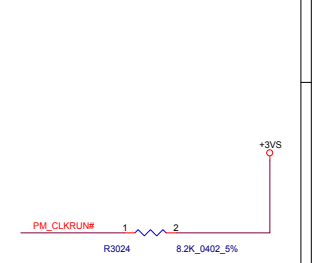
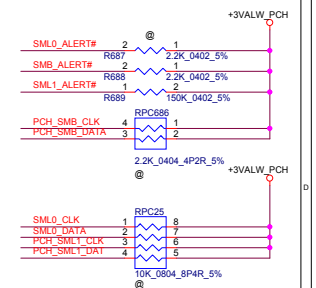
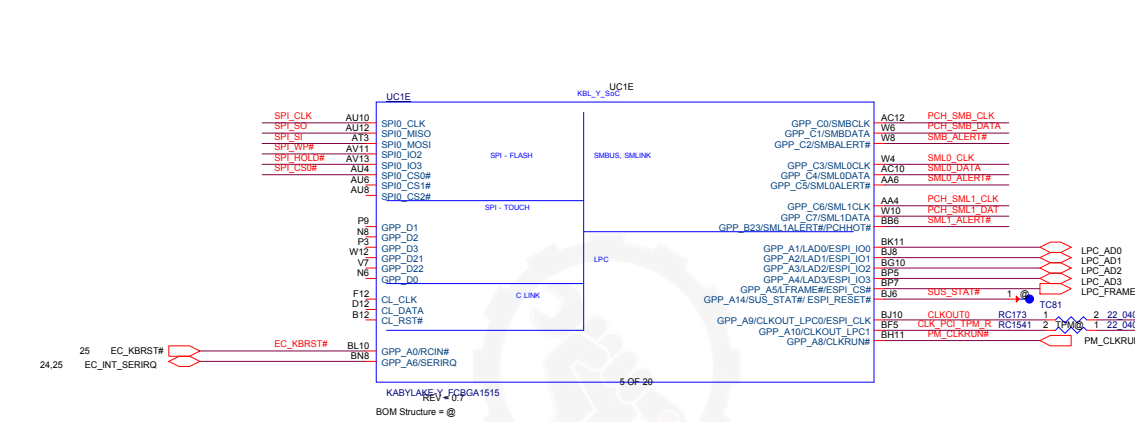
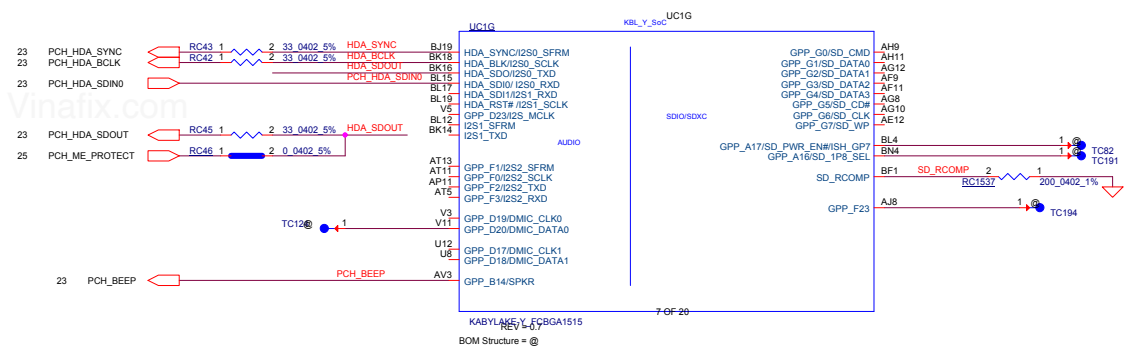
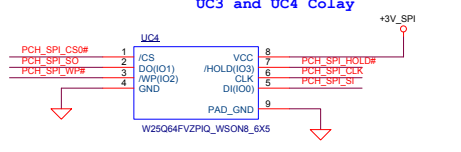
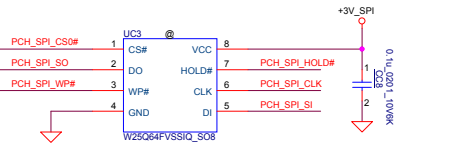
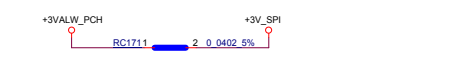
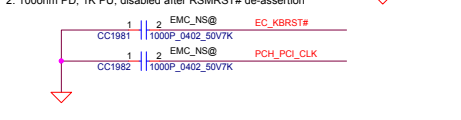
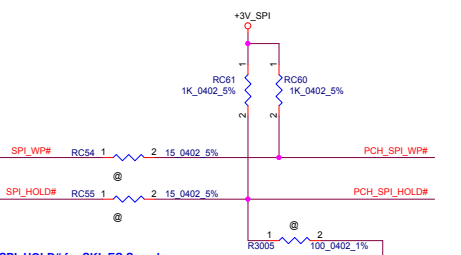
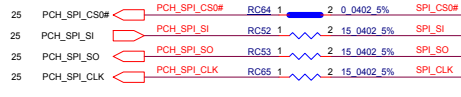
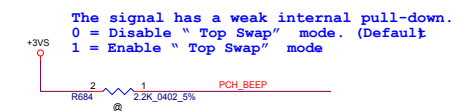
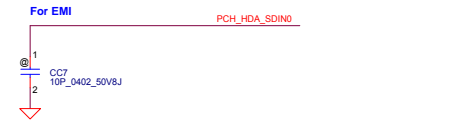
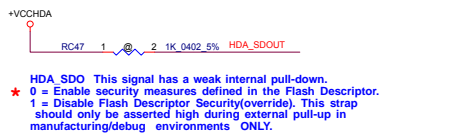

for signal SMB_ALERT#:
 This signal has a weak internal pull-down.
 0 = Disable Intel ME Crypto Transport Layer Security (TLS) cipher suite (no confidentiality). (Default)
 1 = Enable Intel ME Crypto Transport Layer Security (TLS) cipher suite (with confidentiality). Must be pulled up to support Intel AMT with TLS and Intel SBA (Small Business Advantage) with TLS.

Security Classification	LC Future Center Secret Data		Title
Issued Date	2015/11/09	Deciphered Date	2016/06/27
THIS SHEET OF ENGINEERING DRAWING IS THE PROPRIETARY PROPERTY OF LC FUTURE CENTER, AND CONTAINS CONFIDENTIAL AND TRADE SECRET INFORMATION. THIS SHEET MAY NOT BE TRANSFERRED FROM THE CUSTODY OF THE COMPETENT DIVISION OF R&D DEPARTMENT EXCEPT AS AUTHORIZED BY LC FUTURE CENTER. NEITHER THIS SHEET NOR THE INFORMATION IT CONTAINS MAY BE USED BY OR DISCLOSED TO ANY THIRD PARTY WITHOUT PRIOR WRITTEN CONSENT OF LC FUTURE CENTER.			
Size	Document Number		
Date:	Thursday, June 23, 2016	Sheet	7 of 38

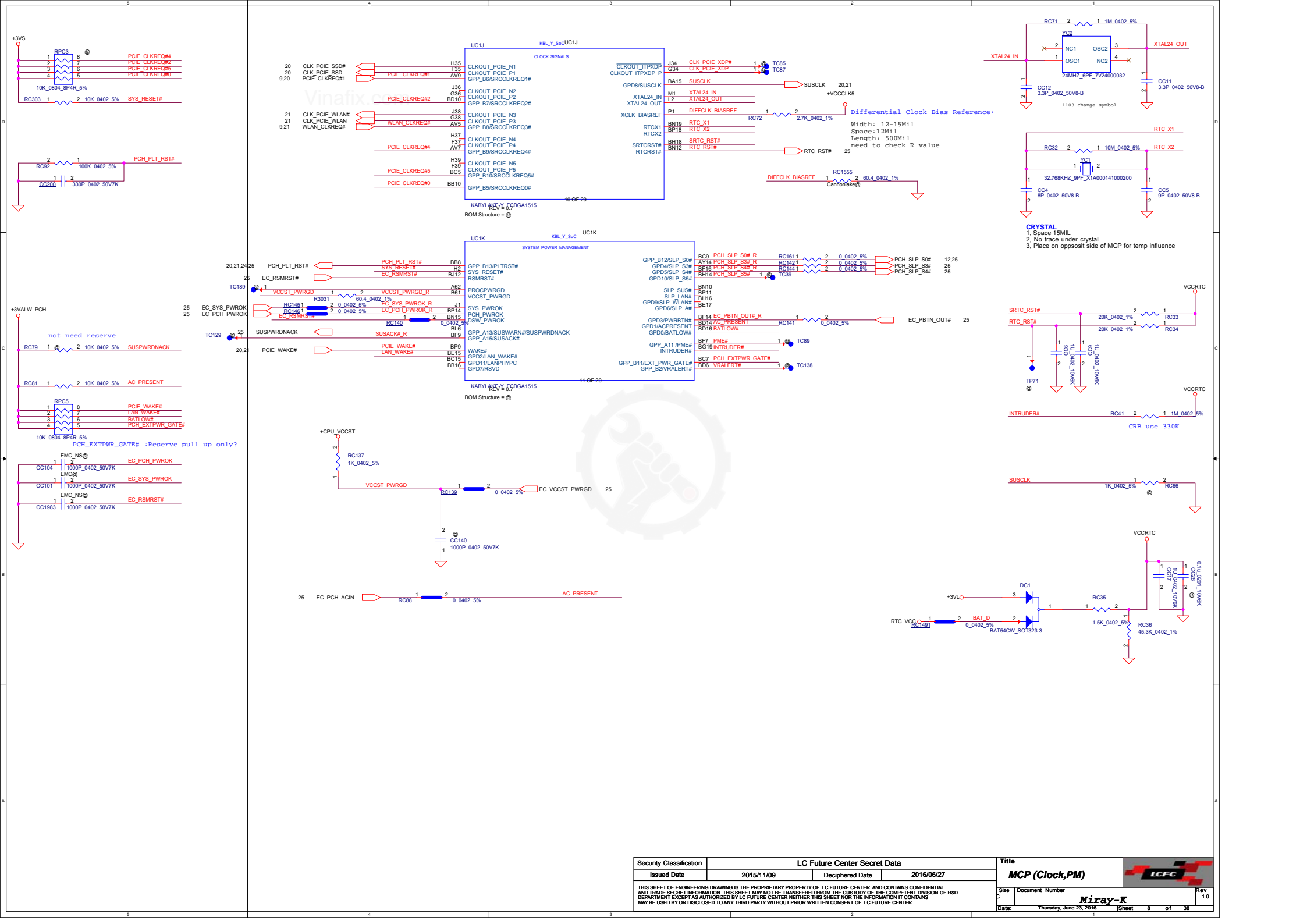

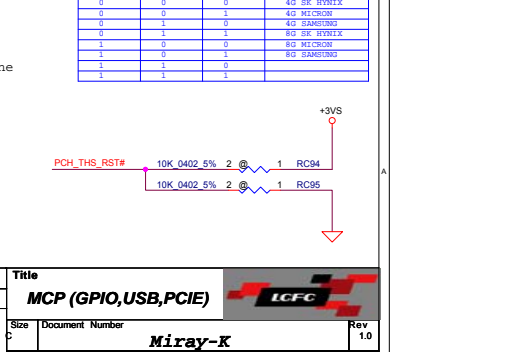
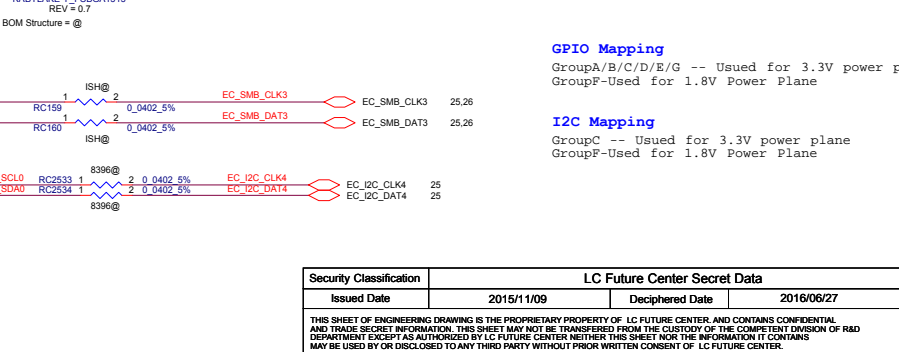
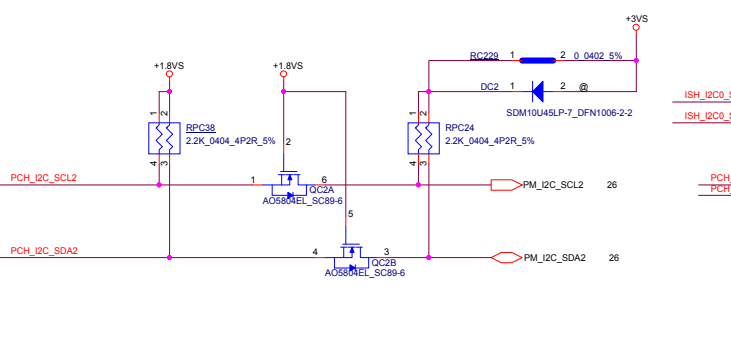
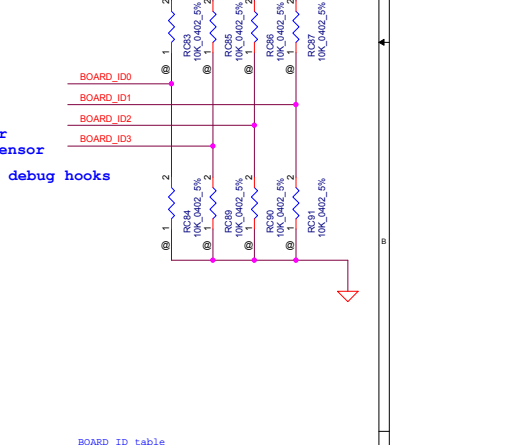
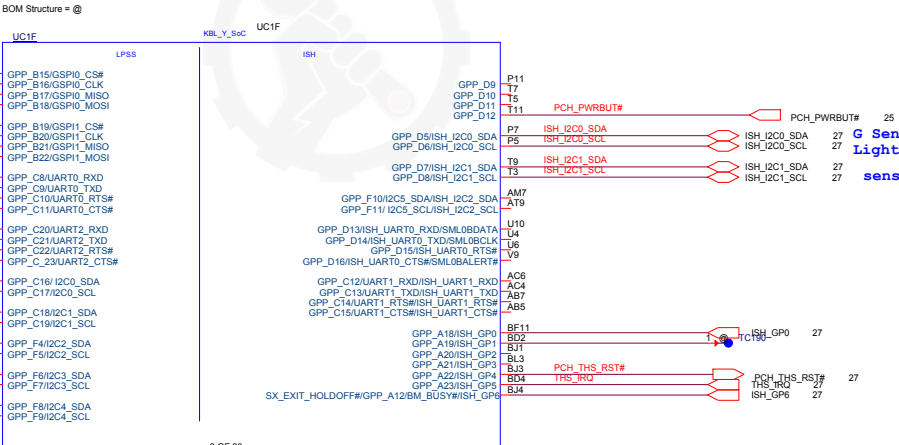
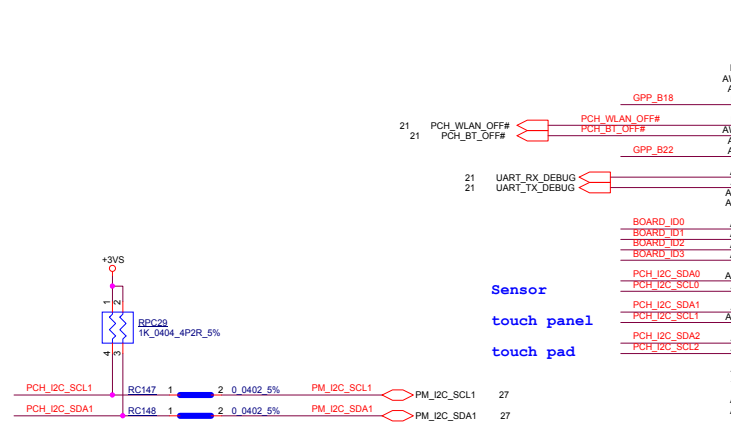
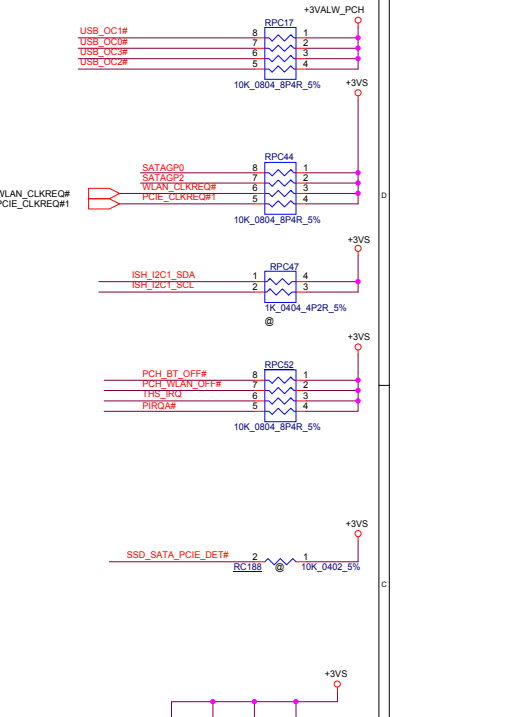
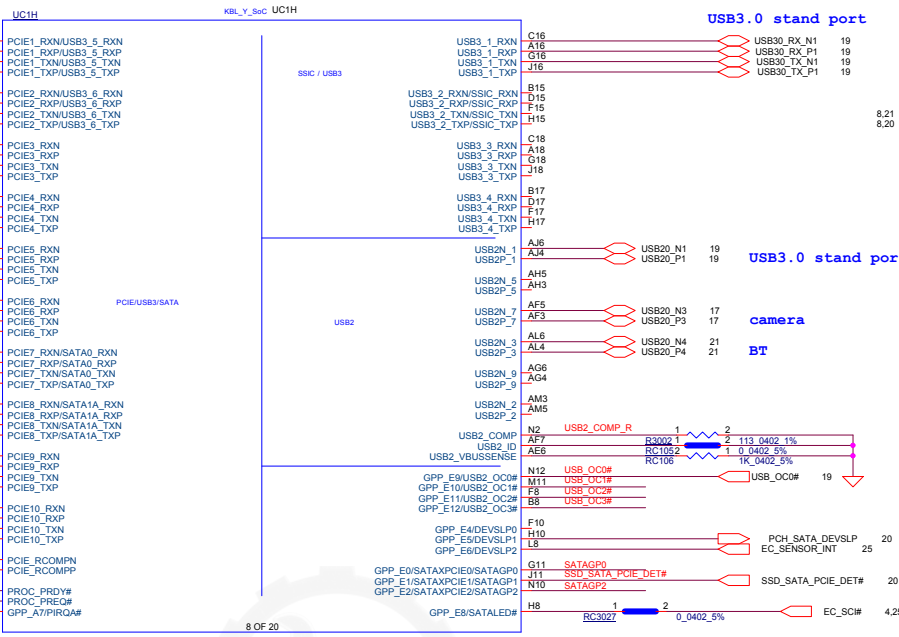
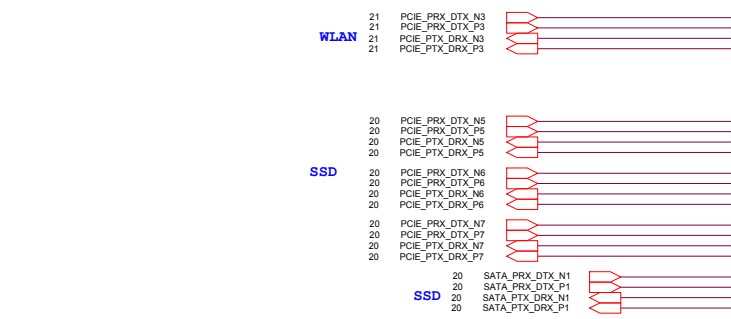
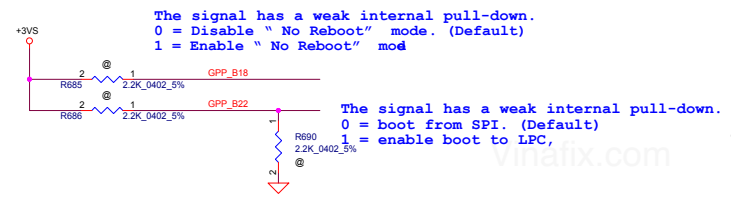

GPIO Mapping
 GroupA/B/C/D/E/G -- Used for 3.3V power plane
 GroupF-Used for 1.8V Power Plane

I2C Mapping
 GroupC -- Used for 3.3V power plane
 GroupF-Used for 1.8V Power Plane

BOARD ID Table

BOARD_ID2	BOARD_ID1	BOARD_ID0	DRAM
0	0	1	4G SE DDR3
0	1	0	4G MDDR3
0	1	1	4G SAMSUNG
1	0	0	8G MDDR3
1	0	1	8G SAMSUNG
1	1	1	

CPU_CFG4
 RC67 1 2
 TK_0402_1%
CFG4 Setting:
 1K PD, used for Enable EDP Panel

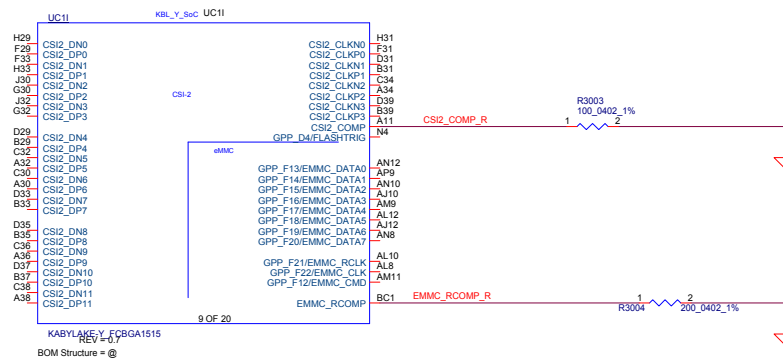
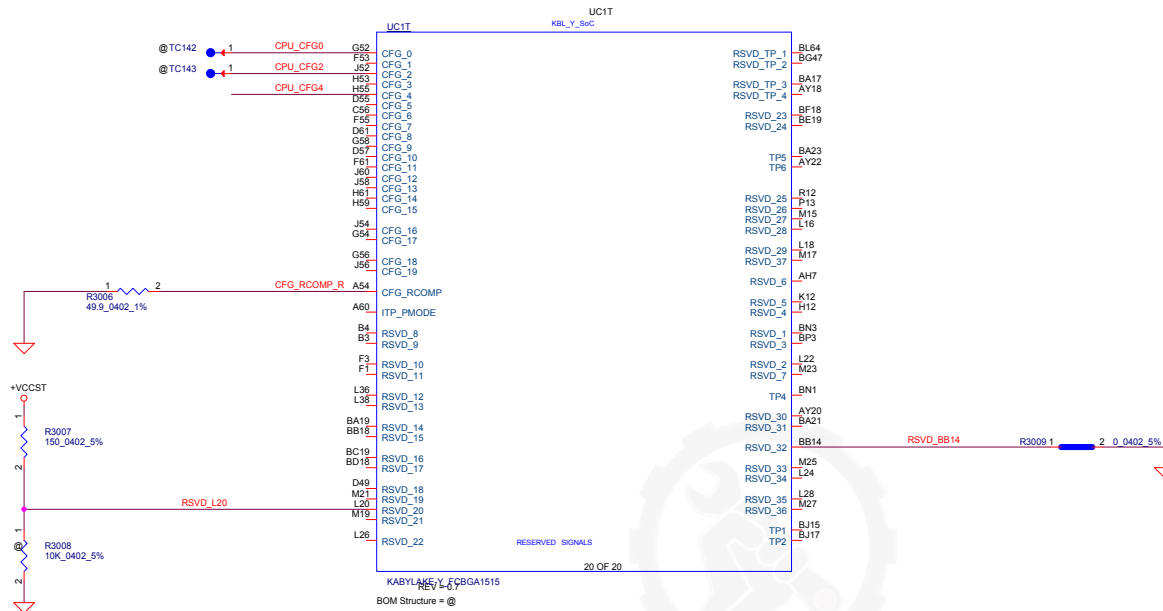

Security Classification		LC Future Center Secret Data		Title	
Issued Date	2015/11/09	Deciphered Date	2016/06/27	MCP (OTHER)	
THIS SHEET OF ENGINEERING DRAWING IS THE PROPRIETARY PROPERTY OF LC FUTURE CENTER, AND CONTAINS CONFIDENTIAL AND TRADE SECRET INFORMATION. THIS SHEET MAY NOT BE TRANSFERRED FROM THE CUSTODY OF THE COMPETENT DIVISION OF R&D DEPARTMENT EXCEPT AS AUTHORIZED BY LC FUTURE CENTER. NEITHER THIS SHEET NOR THE INFORMATION IT CONTAINS MAY BE USED BY OR DISCLOSED TO ANY THIRD PARTY WITHOUT PRIOR WRITTEN CONSENT OF LC FUTURE CENTER.					
Size	Document Number	Rev		1.0	
Date:	Thursday, June 23, 2016	Sheet	10	of	38

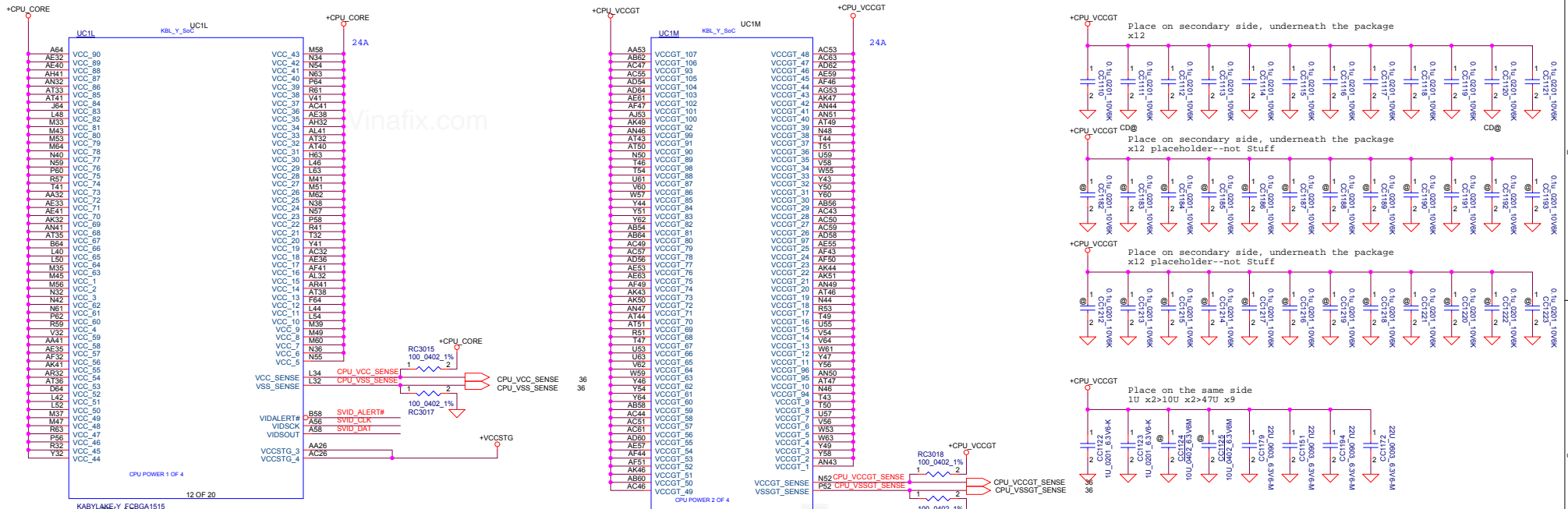

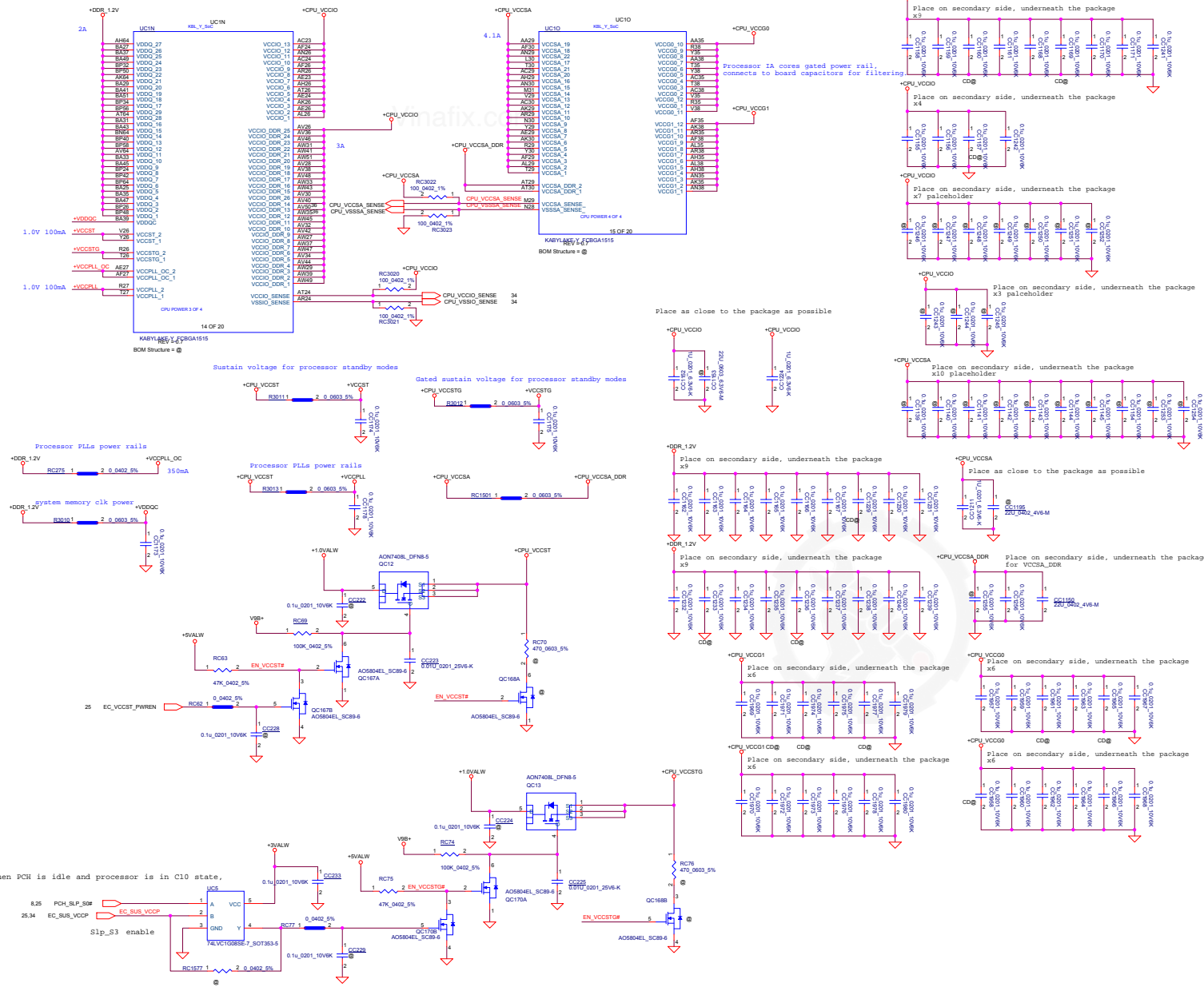

VCCST : Sustain voltage for processor in Standby modes
 VCCPLL : CPU PLL power rails
 VCCPLL_OC : CPU digital PLL power rails
 VCCSTG : Gated version of VCCST

Security Classification		LC Future Center Secret Data		Title	
Issued Date	2015/11/09	Deciphered Date	2016/06/27	MCP(Power1)	
<small>THIS SHEET OF ENGINEERING DRAWINGS IS THE PROPRIETARY PROPERTY OF LC FUTURE CENTER, AND CONTAINS CONFIDENTIAL AND TRADE SECRET INFORMATION. THIS SHEET MAY NOT BE TRANSMITTED FROM THE CUSTODY OF THE COMPANY DIVISION OF IAD DEPARTMENT WITHOUT APPROVAL BY LC FUTURE CENTER. NEITHER THIS SHEET NOR THE INFORMATION IT CONTAINS MAY BE USED BY OR DISCLOSED TO ANY THIRD PARTY WITHOUT PRIOR WRITTEN CONSENT OF LC FUTURE CENTER.</small>					
File Name	Document Number	Revision		Page	
Miray-K		119		119 of 180	
Date	Thursday, June 25, 2015	Sheet	12	of 38	

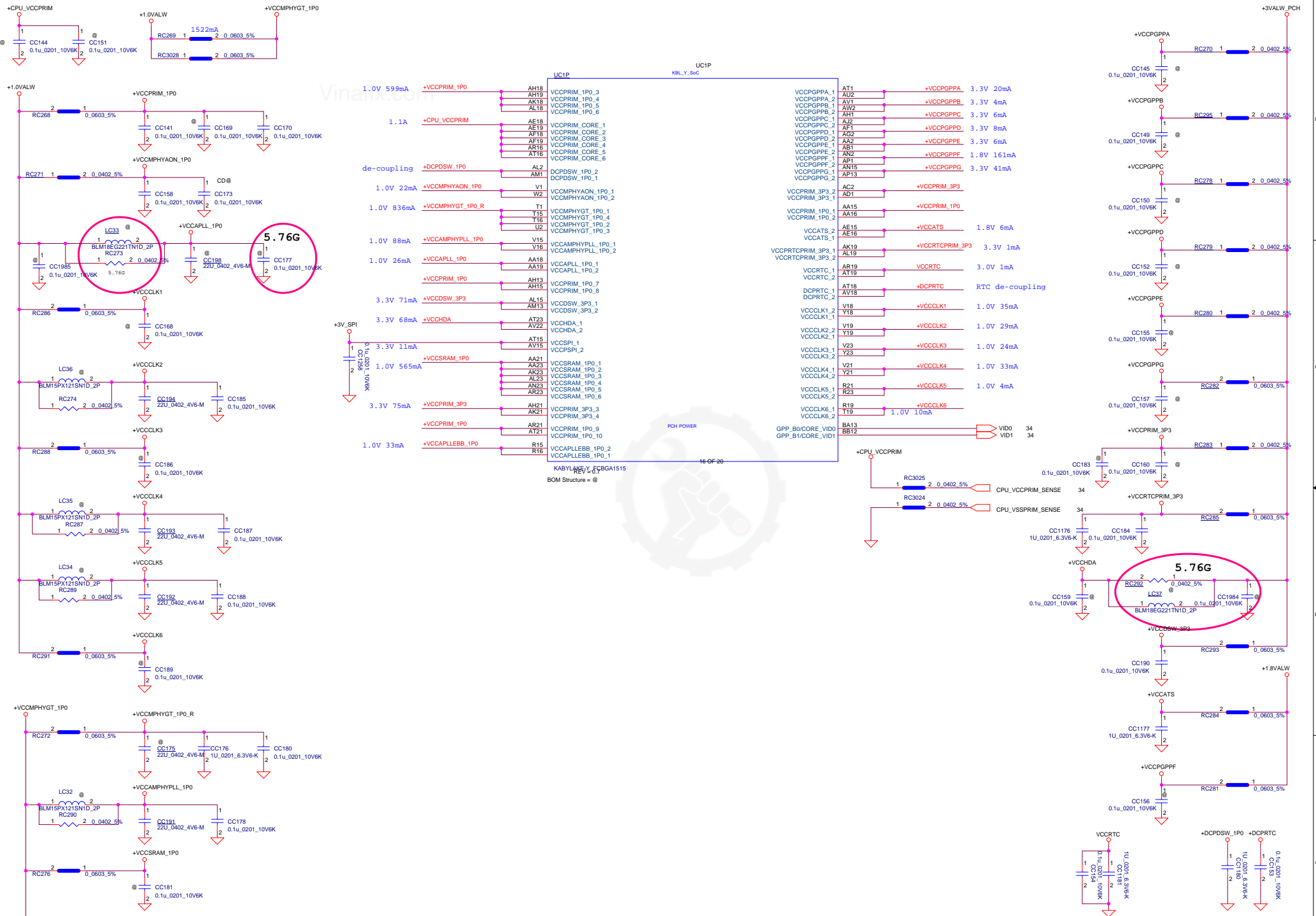

UC1Q
KBL_Y_Soc

A14	VSS_412	VSS_342	K23
AA7	VSS_411	VSS_341	K43
AA7	VSS_411	VSS_341	K43
AA5	VSS_409	VSS_339	K53
AA5	VSS_409	VSS_339	K53
AC15	VSS_408	VSS_338	N20
AC27	VSS_407	VSS_337	L61
AE1C	VSS_406	VSS_336	R24
AE43	VSS_405	VSS_335	R40
AE50	VSS_404	VSS_334	R40
AF1B	VSS_403	VSS_333	T13
AF40	VSS_402	VSS_332	T33
AF62	VSS_401	VSS_331	E26
AF23	VSS_400	VSS_330	V27
AH40	VSS_399	VSS_329	V43
AH49	VSS_398	VSS_328	Y15
AK1	VSS_397	VSS_327	Y3
AK24	VSS_396	VSS_326	Y9
AK40	VSS_395	VSS_325	AA24
AL33	VSS_394	VSS_324	AA40
AL46	VSS_393	VSS_323	AA59
AL53	VSS_392	VSS_322	AC16
AN18	VSS_391	VSS_321	AC33
AN33	VSS_390	VSS_320	AE2
AP64	VSS_389	VSS_319	AE44
AR2	VSS_388	VSS_318	E51
AR4	VSS_387	VSS_317	AF21
AR4	VSS_386	VSS_316	AF4
AR4	VSS_385	VSS_315	AF64
AR6	VSS_384	VSS_314	AH27
AJ35	VSS_383	VSS_313	AH43
AV16	VSS_382	VSS_312	AH50
AV17	VSS_381	VSS_311	AK11
AI16	VSS_380	VSS_310	AK27
AY32	VSS_379	VSS_309	AK5
AY42	VSS_378	VSS_308	AL21
AY52	VSS_377	VSS_307	AL36
BA5	VSS_376	VSS_306	AL47
BA9	VSS_375	VSS_304	AL59
BB38	VSS_374	VSS_303	AN19
BB48	VSS_373	VSS_302	AN36
BB48	VSS_372	VSS_301	AR10
BC11	VSS_371	VSS_300	AR27
BD56	VSS_369	VSS_299	AR40
BE33	VSS_368	VSS_298	AR9
BF45	VSS_367	VSS_297	AU57
BG8	VSS_366	VSS_296	AV20
BH28	VSS_365	VSS_295	AV19
BH40	VSS_364	VSS_294	AY24
BH50	VSS_363	VSS_293	AY34
BS5	VSS_362	VSS_292	AY44
BU29	VSS_361	VSS_291	BA53
BM16	VSS_360	VSS_290	BB20
BP36	VSS_359	VSS_289	BB30
BP64	VSS_358	VSS_288	BB40
BT1	VSS_357	VSS_287	BS50
E14	VSS_356	VSS_286	BC29
E24	VSS_355	VSS_285	BD63
E34	VSS_354	VSS_284	BE35
E44	VSS_353	VSS_283	BG29
E54	VSS_352	VSS_282	BG35
J14	VSS_351	VSS_281	BF59
J9	VSS_350	VSS_280	BP4
AH47	VSS_349	VSS_279	AL30
AJ59	VSS_348	VSS_278	AL51
AK16	VSS_347	VSS_277	AL15
AK36	VSS_346	VSS_276	AN16
AK9	VSS_345	VSS_275	AN27
V24	VSS_344	VSS_274	BA7
V24	VSS_343	VSS_273	BA7

GND 1 OF 3
17 OF 20
KABYLAKE_Y_FCBGA1515
REV 1.0
BOM Structure = @

UC1R
KBL_Y_Soc

BH20	VSS_271	VSS_274	AR50
BH22	VSS_270	VSS_202	A177
BH22	VSS_270	VSS_201	AU59
BH22	VSS_269	VSS_200	AV24
BH52	VSS_268	VSS_199	AW21
BL1	VSS_267	VSS_198	AY26
BL7	VSS_266	VSS_198	AY26
BM18	VSS_265	VSS_197	AY26
BN6	VSS_264	VSS_196	BA1
BP38	VSS_263	VSS_196	BA27
BP60	VSS_262	VSS_194	BB22
E16	VSS_261	VSS_193	BB32
E26	VSS_260	VSS_192	BB20
E36	VSS_259	VSS_191	BB22
E46	VSS_258	VSS_189	BC47
E56	VSS_257	VSS_189	BE15
J3	VSS_256	VSS_188	BE47
K15	VSS_255	VSS_187	BE12
K25	VSS_254	VSS_186	BE12
K35	VSS_253	VSS_185	BH22
K45	VSS_252	VSS_184	BH44
K55	VSS_251	VSS_183	BH44
M3	VSS_250	VSS_182	BH44
N22	VSS_249	VSS_181	BH44
N22	VSS_248	VSS_180	BY28
N22	VSS_247	VSS_179	BY28
R43	VSS_246	VSS_178	BY28
R50	VSS_245	VSS_177	BP44
R18	VSS_244	VSS_176	BP44
R36	VSS_243	VSS_175	BP44
V30	VSS_242	VSS_174	BE8
V44	VSS_241	VSS_173	E38
V51	VSS_240	VSS_172	E38
V16	VSS_239	VSS_171	E48
V36	VSS_238	VSS_170	E59
V7	VSS_237	VSS_169	J6
AX27	VSS_236	VSS_168	K17
AA43	VSS_235	VSS_167	K27
AA50	VSS_234	VSS_166	K37
AA61	VSS_233	VSS_165	K47
AC18	VSS_232	VSS_164	L14
AC36	VSS_231	VSS_163	N14
AE21	VSS_230	VSS_162	N24
AE46	VSS_229	VSS_161	N33
AE9	VSS_228	VSS_160	R44
AF23	VSS_227	VSS_159	T21
AF56	VSS_226	VSS_158	T64
AG59	VSS_225	VSS_157	V33
AH30	VSS_224	VSS_156	V46
AH44	VSS_223	VSS_155	Y1
AE11	VSS_222	VSS_154	Y24
AK13	VSS_221	VSS_153	Y40
AK3	VSS_220	VSS_152	AA30
AK54	VSS_219	VSS_151	AA44
AL24	VSS_218	VSS_150	AA51
AL40	VSS_217	VSS_149	AA63
AL49	VSS_216	VSS_148	AA63
AM54	VSS_215	VSS_147	AE30
AN21	VSS_214	VSS_146	AE30
AN40	VSS_213	VSS_145	AE47
AR12	VSS_212	VSS_144	AF13
AR20	VSS_211	VSS_143	AU33
AR43	VSS_210	VSS_142	AV25
AP44	VSS_209	VSS_141	AV54
AR18	VSS_208	VSS_140	AV25
AR36	VSS_207	VSS_139	AV50
AR46	VSS_206	VSS_138	AV50
AR59	VSS_205	VSS_137	AV50
AS24	VSS_204	VSS_136	AV50
BA3	VSS_203	VSS_135	AV50

GND 2 OF 3
18 OF 20
KABYLAKE_Y_FCBGA1515
REV 1.0
BOM Structure = @

UC1S
KBL_Y_Soc

AF33	VSS_9	VSS_73	R46
AF53	VSS_10	VSS_74	R6
AH16	VSS_11	VSS_75	T23
AH33	VSS_12	VSS_76	T5
AH46	VSS_13	VSS_134	V36
AH54	VSS_14	VSS_135	V13
AK15	VSS_15	VSS_136	V13
AK23	VSS_16	VSS_137	Y11
AK7	VSS_17	VSS_138	Y27
AL27	VSS_18	VSS_139	Y48
AL43	VSS_19	VSS_140	BB26
AL50	VSS_20	VSS_141	BB36
AL64	VSS_21	VSS_142	BB46
AN24	VSS_22	VSS_81	BB59
AN59	VSS_23	VSS_82	BD39
AV92	VSS_24	VSS_83	BD39
AR33	VSS_25	VSS_84	BF38
AR44	VSS_26	VSS_85	BG17
AR51	VSS_27	VSS_86	BG43
AT54	VSS_28	VSS_87	BH26
AW61	VSS_29	VSS_88	BH48
AW23	VSS_30	VSS_89	BH59
AY28	VSS_31	VSS_90	BP38
AY38	VSS_32	VSS_91	BP38
AY48	VSS_33	VSS_92	BP38
BA11	VSS_34	VSS_93	BM14
BA44	VSS_35	VSS_94	BN29
BB24	VSS_36	VSS_95	BP20
BB54	VSS_37	VSS_96	BP22
BB44	VSS_38	VSS_97	C40
BB54	VSS_39	VSS_98	D8
BD20	VSS_40	VSS_99	E22
BE29	VSS_41	VSS_100	E32
BP20	VSS_42	VSS_101	E42
BP15	VSS_43	VSS_102	E52
BP20	VSS_44	VSS_103	G14
BP20	VSS_45	VSS_104	J7
BP24	VSS_46	VSS_105	K21
BH56	VSS_47	VSS_106	K31
BH46	VSS_48	VSS_107	K41
BH56	VSS_49	VSS_108	K51
BL31	VSS_50	VSS_109	L59
BM11	VSS_51	VSS_110	N18
BM98	VSS_52	VSS_111	P54
BP28	VSS_53	VSS_112	R2
BP46	VSS_54	VSS_113	R4
CT4	VSS_55	VSS_114	R7
D62	VSS_56	VSS_115	R40
E20	VSS_57	VSS_116	T24
E30	VSS_58	VSS_117	T58
E40	VSS_59	VSS_118	Y3
E50	VSS_60	VSS_119	AA33
E62	VSS_61	VSS_120	AA45
K19	VSS_62	VSS_121	AA46
K29	VSS_63	VSS_122	AB13
K39	VSS_64	VSS_123	AC21
K49	VSS_65	VSS_124	AD13
L57	VSS_66	VSS_125	AE4
N16	VSS_67	VSS_126	AE49
N26	VSS_68	VSS_127	AF15
R18	VSS_69	VSS_128	AF36
R36	VSS_70	VSS_129	AF60
AV40	VSS_71	VSS_130	AH23
V49	VSS_72	VSS_131	BP1
Y13	VSS_73	VSS_132	AS
Y30	VSS_74	VSS_133	D1
V40	VSS_75	VSS_134	VSS_1
V40	VSS_76	VSS_135	BP62

GND 3 OF 3
19 OF 20
KABYLAKE_Y_FCBGA1515
REV 1.0
BOM Structure = @

Security Classification	LC Future Center Secret Data		Title
Issued Date	2015/11/09	Deciphered Date	2016/06/27
THIS SHEET OF ENGINEERING DRAWINGS IS THE PROPRIETARY PROPERTY OF LC FUTURE CENTER, AND CONTAINS CONFIDENTIAL AND TRADE SECRET INFORMATION. THIS SHEET MAY NOT BE TRANSFERRED FROM THE CUSTODY OF THE COMPETENT DIVISION OF R&D DEPARTMENT EXCEPT AS AUTHORIZED BY LC FUTURE CENTER. NEITHER THIS SHEET NOR THE INFORMATION IT CONTAINS MAY BE USED BY OR DISCLOSED TO ANY THIRD PARTY WITHOUT PRIOR WRITTEN CONSENT OF LC FUTURE CENTER.			
Size	Document Number	Miray-K	
Date:	Thursday, June 23, 2016	Sheet	14 of 38
Rev	1.0		

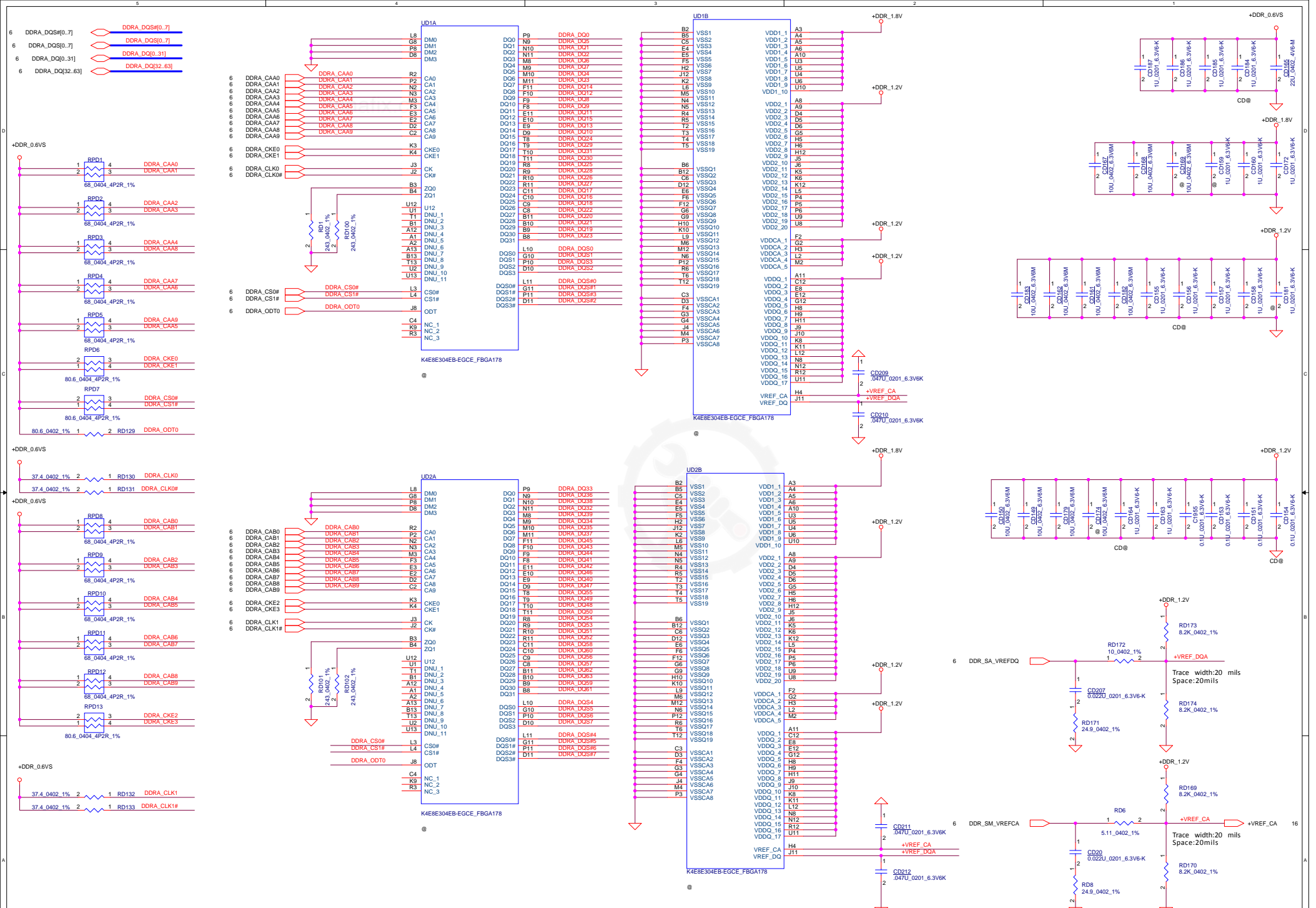

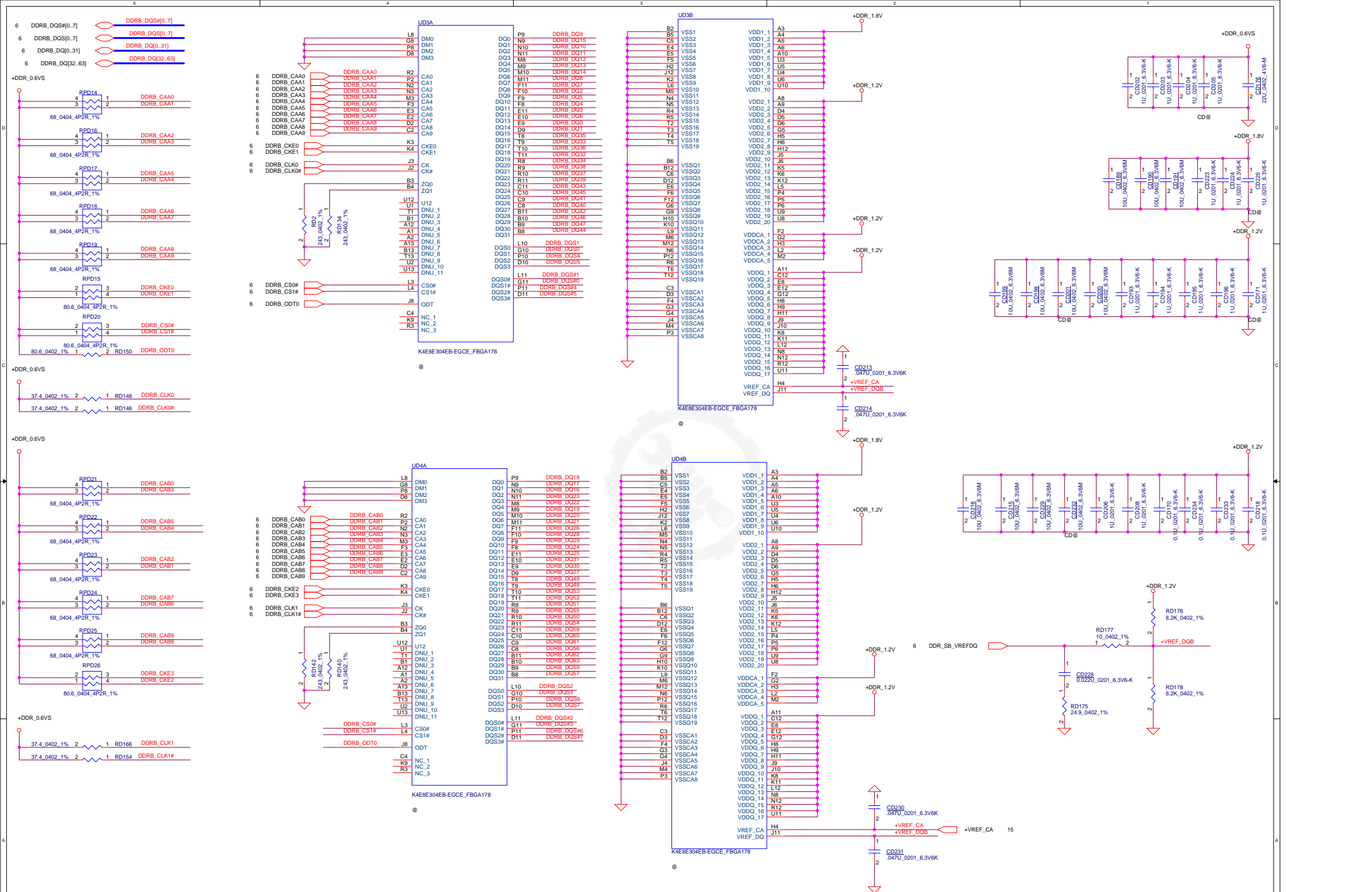

EDP Panel

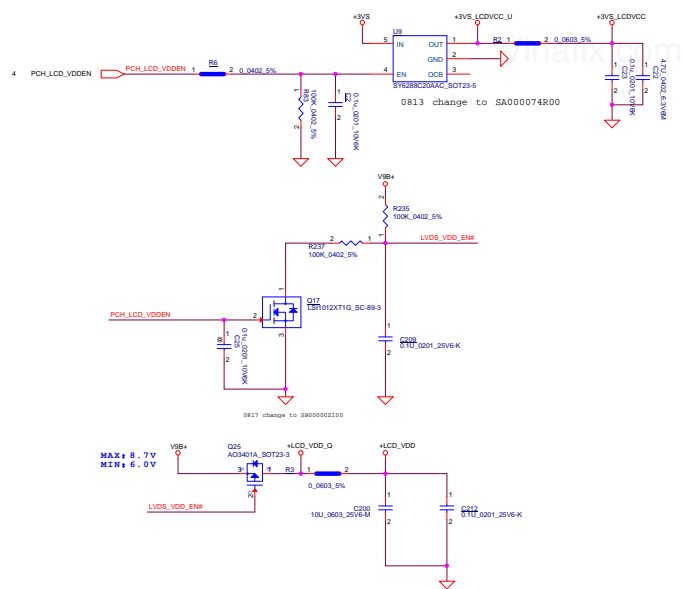

- NOTE**
1. AC 13V/DC 8.2V
 2. A058002 For VDS concern
 3. R235, R237 For VDS concern
 4. C200 For voltage concern

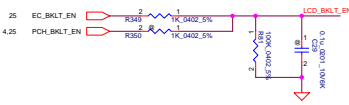
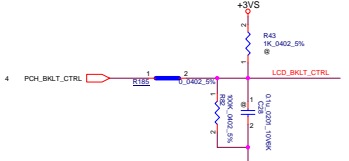

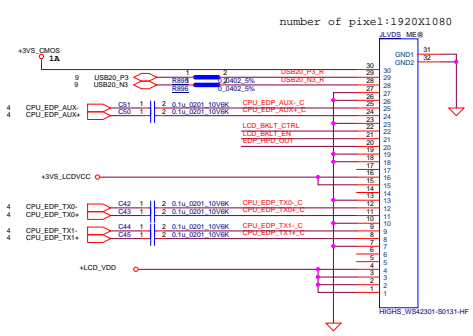
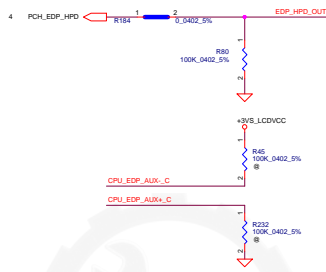

FPC:
 1. pin to pin with EDP Panel, check the panel pin definition
 2. check the HSYNC for Touch screen board

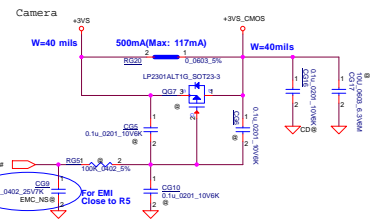

1106 symbol update



Reserve for other function

Security Classification	LC Future Center Secret Data		Title	
Issued Date	2015/1/09	Deciphered Date	2016/08/27	
<small>THIS SHEET OF ENGINEERING DRAWINGS IS THE PROPRIETARY PROPERTY OF LC FUTURE CENTER, AND CONTAINS CONFIDENTIAL AND TRADE SECRET INFORMATION. THIS SHEET MAY NOT BE TRANSMITTED FROM THE CUSTODY OF THE COMPETENT PERSON OF R&D DEPARTMENT EXCEPT AS AUTHORIZED BY LC FUTURE CENTER. WITHIN THE SHEET AND THE INFORMATION IT CONTAINS MAY BE USED BY OR DISCLOSED TO ANY THIRD PARTY WITHOUT PRIOR WRITTEN CONSENT OF LC FUTURE CENTER.</small>				
Size	Document Number	Rev		
Date	Thursday, June 25, 2016	Issue	17	of 38

4	CPU_HDMI_TX0+	CPU_HDMI_TX0+	CV255 1	2	0.1u_0201_10V8K	HDMI_TX0+_C
4	CPU_HDMI_TX0-	CPU_HDMI_TX0-	CV256 1	2	0.1u_0201_10V8K	HDMI_TX0-_C
4	CPU_HDMI_TX1+	CPU_HDMI_TX1+	CV257 1	2	0.1u_0201_10V8K	HDMI_TX1+_C
4	CPU_HDMI_TX1-	CPU_HDMI_TX1-	CV258 1	2	0.1u_0201_10V8K	HDMI_TX1-_C
4	CPU_HDMI_TX2+	CPU_HDMI_TX2+	CV259 1	2	0.1u_0201_10V8K	HDMI_TX2+_C
4	CPU_HDMI_TX2-	CPU_HDMI_TX2-	CV260 1	2	0.1u_0201_10V8K	HDMI_TX2-_C
4	CPU_HDMI_CLK+	CPU_HDMI_CLK+	CV261 1	2	0.1u_0201_10V8K	HDMI_CLK+_C
4	CPU_HDMI_CLK-	CPU_HDMI_CLK-	CV262 1	2	0.1u_0201_10V8K	HDMI_CLK-_C

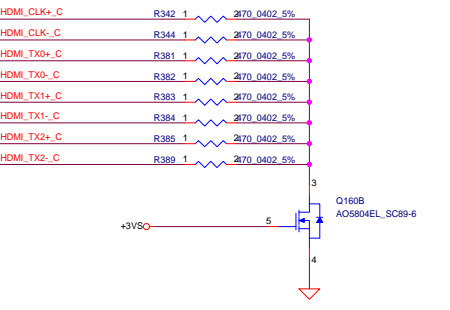
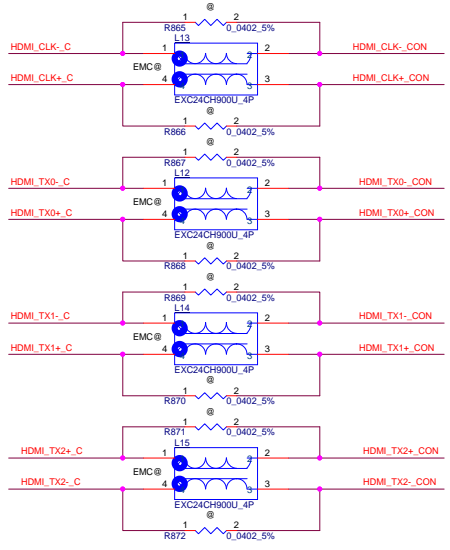

DDC

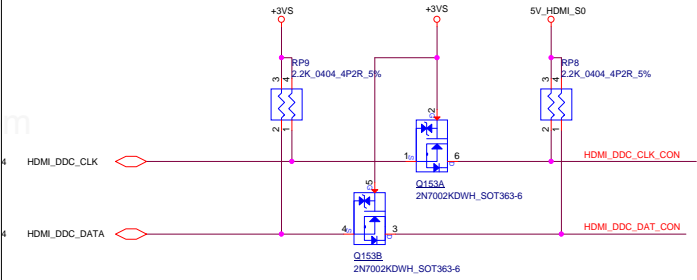

H-PLUG

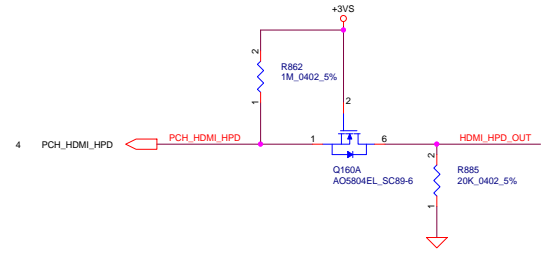

CONN

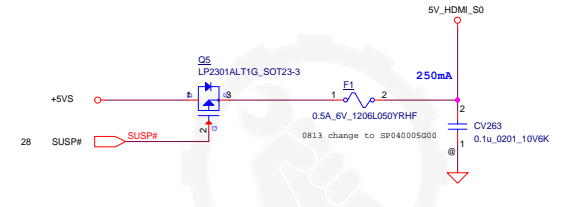

HDMI Type D

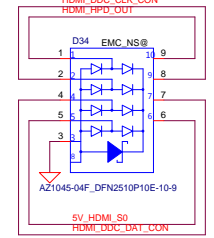
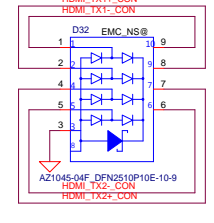
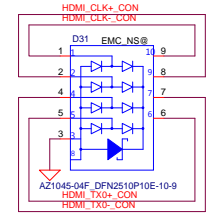
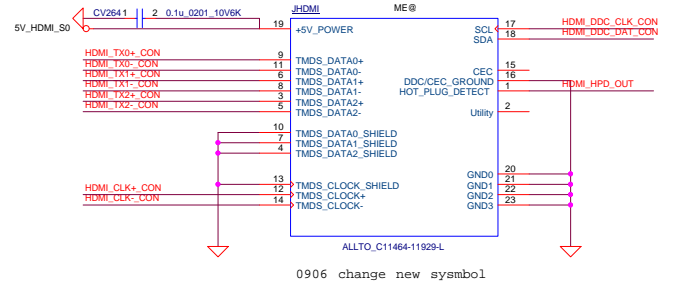

USB30

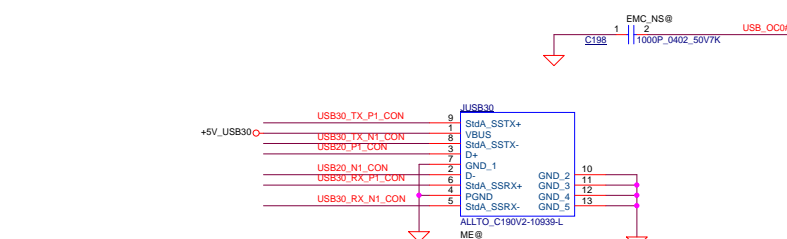
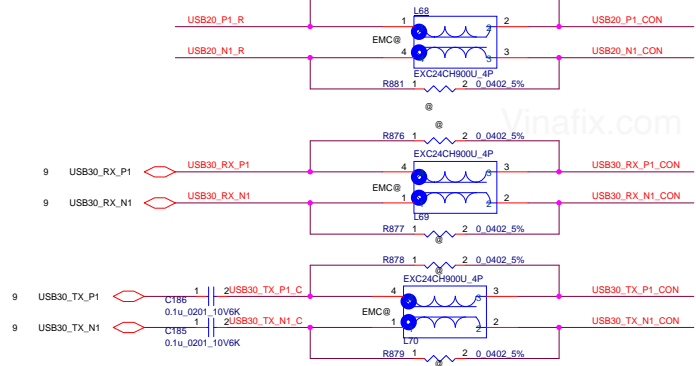

1105 change new symbol

USB type A

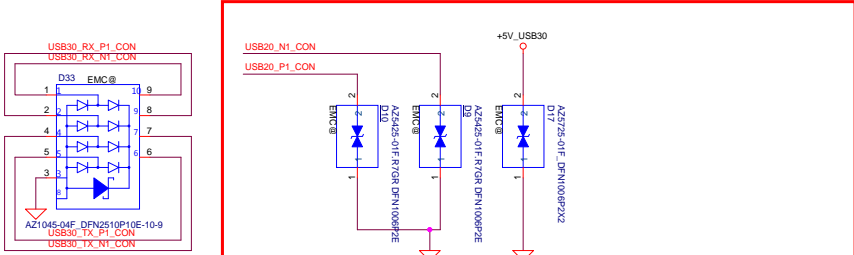

2016/04/20:USB 2.0 port TVS ref location
 D9 & D10 change to SC400006510:
 SC400006510 S DIO_ESD AZ5425-01F.R7GR DFN1006P2E
 2016/05/10:USB 3.0 port TVS ref location
 D17 change to SC400008K00
 S DIO_ESD AZ5725-01F.R7GR DFN1006P2X

USB charger

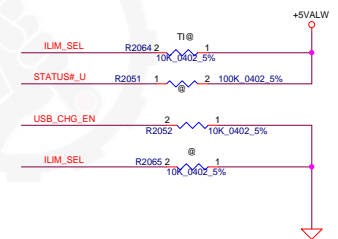
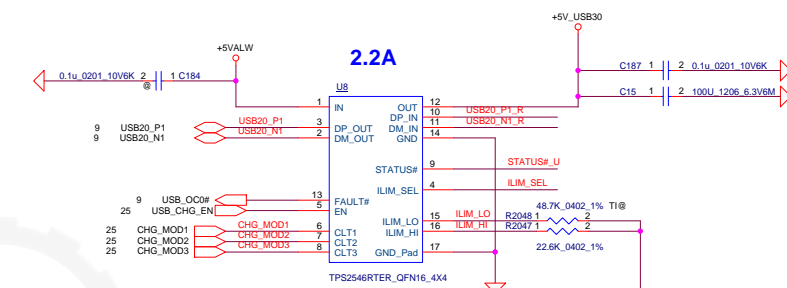

	pin number	6	7	8	4
	pin name	Ct11	Ct12	Ct13	ILM_SEL
Charge port Pin5 Enable H for all	S0 CDP	1	1	1	1
	S3 DCP	0	1	1	0/1
	S4/S5 DCP	0	0	1	0/1
Normal port Pin5 Enable H for S0/S3 L for S4/S5	S0 SDP1	1	1	0	0/1
	S3 SDP1	0	1	0	0/1
	S4/S5 Disable	0	0	0	0/1

Vinafix.com

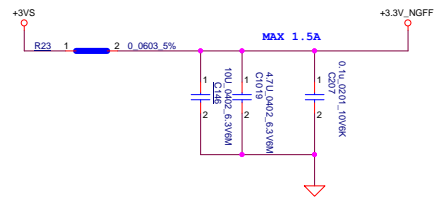

SSD	C1978	C1979	C1980	C1981	C1982	C1983	C1947	C1946	C1944	C1945
PCIe	Stuff 0.22µF SE00000X800	Stuff 0.22µF SE00000X800	Stuff 0.22µF SE00000X800	Stuff 0.22µF SE00000X800	Stuff 0.22µF SE00000X800	Stuff 0.22µF SE00000X800	Stuff 0.04µF SE0280000R7	Stuff 0.04µF SE0280000R7	Stuff 0.22µF SE00000X800	Stuff 0.22µF SE00000X800
SATA	Stuff 0.22µF SE00000X800	Stuff 0.22µF SE00000X800	Stuff 0.22µF SE00000X800	Stuff 0.22µF SE00000X800	Stuff 0.22µF SE00000X800	Stuff 0.22µF SE00000X800	Stuff 0.01µF SE075103K67	Stuff 0.01µF SE075103K67	Stuff 0.01µF SE075103K67	Stuff 0.01µF SE075103K67

Default stuff SATA option
SDV rework to PCIe option and test SATA/PCIe signal and SSD

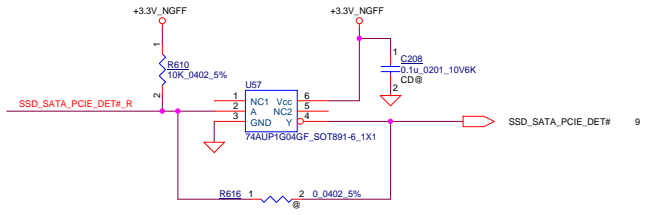
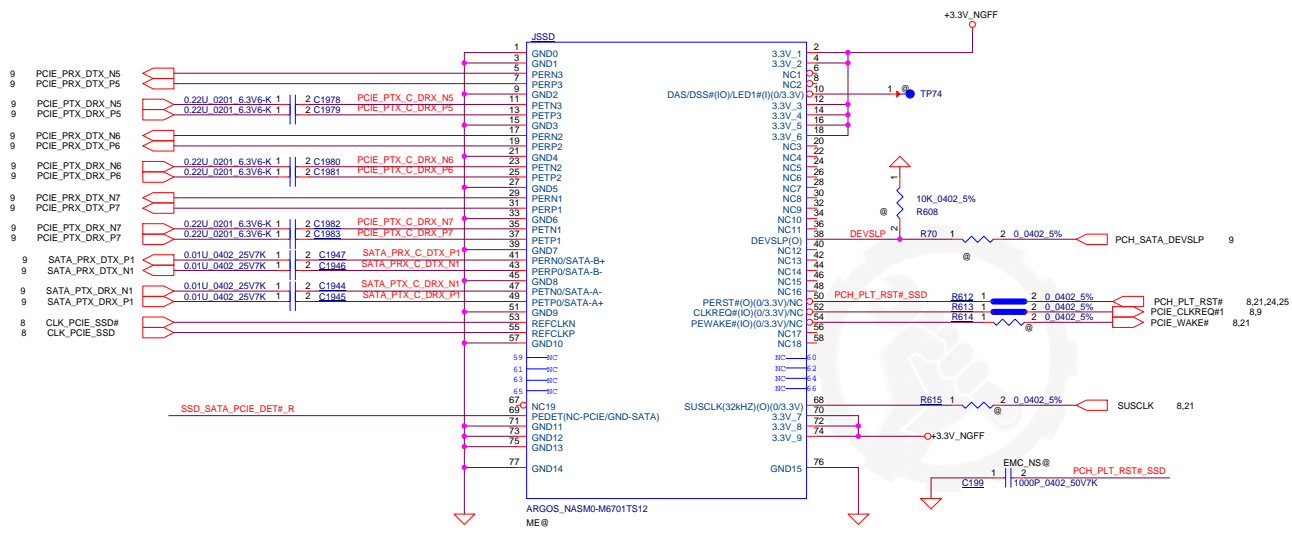

Mini Card(WLAN/WiMAX)

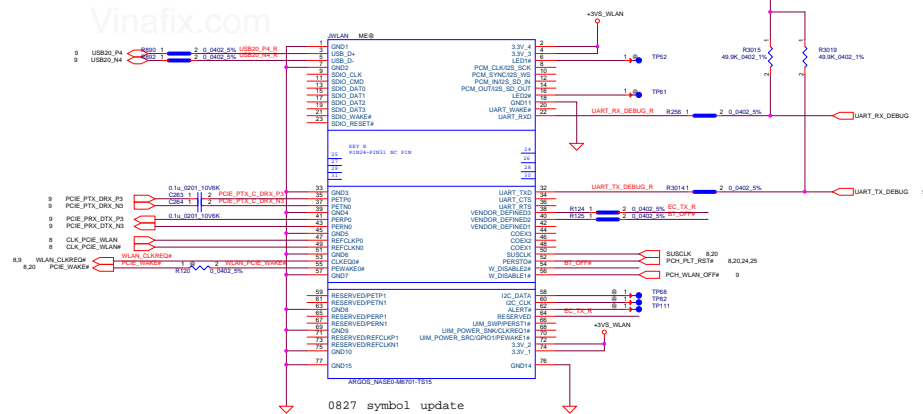
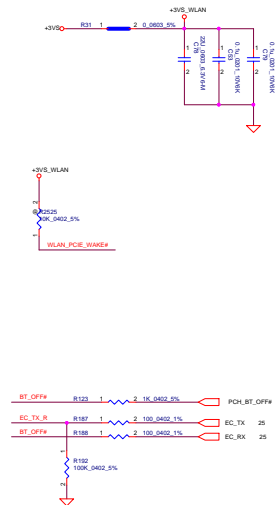

WLAN&BT Combo module circuits

	BT on module Enable	BT on module Disable
* BT_CTRL	H	L
PCH_BT_ON#	L	H



Vinafix.com

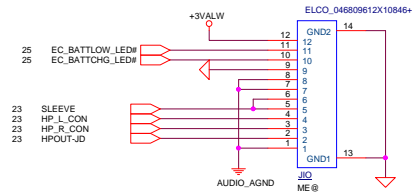

0111 symbol update



Security Classification	LC Future Center Secret Data		Title	
Issued Date	2015/11/09	Deciphered Date	2016/06/27	
THIS SHEET OF ENGINEERING DRAWING IS THE PROPRIETARY PROPERTY OF LC FUTURE CENTER, AND CONTAINS CONFIDENTIAL AND TRADE SECRET INFORMATION. THIS SHEET MAY NOT BE TRANSFERRED FROM THE CUSTODY OF THE COMPETENT DIVISION OF RAD DEPARTMENT EXCEPT AS AUTHORIZED BY LC FUTURE CENTER. NEITHER THIS SHEET NOR THE INFORMATION IT CONTAINS MAY BE USED BY OR DISCLOSED TO ANY THIRD PARTY WITHOUT PRIOR WRITTEN CONSENT OF LC FUTURE CENTER.				
Size	Document Number	Rev		
Custom	Miray-K	1.0		
Date:	Thursday, June 23, 2016	Sheet	22	of 38

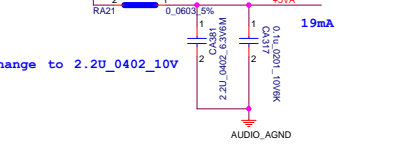
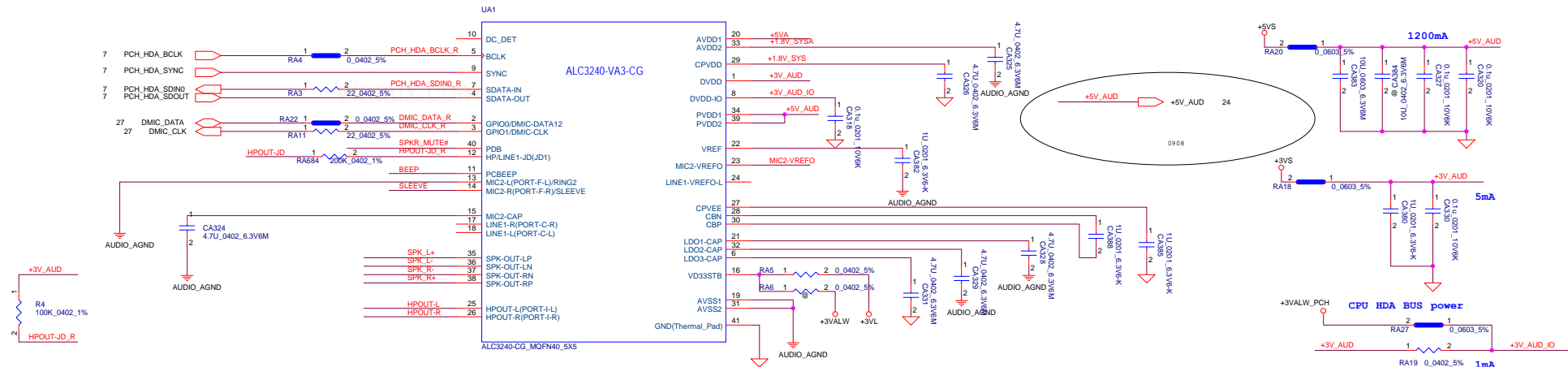

VD33STB: Power for combo jack depop circuit at system shutdown mode.
 AVDD1: Analog power for mixers ,IO ports
 DVDD-IO: Digital power for HDA link
 DVDD: Digital power for digital I/O circuit
 AVDD2: Analog power for DACS ,ADCS
 PVDD1,PVDD2: Power supply for full-bridge left and right channel

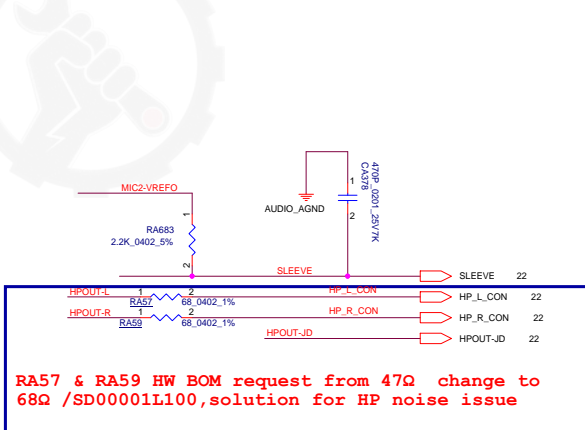
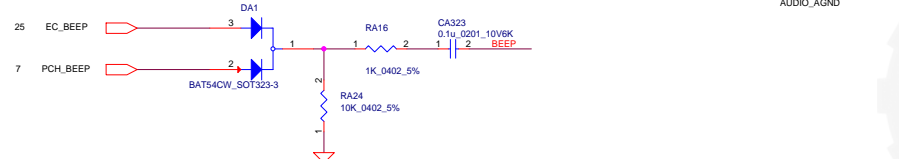
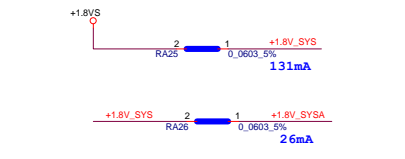
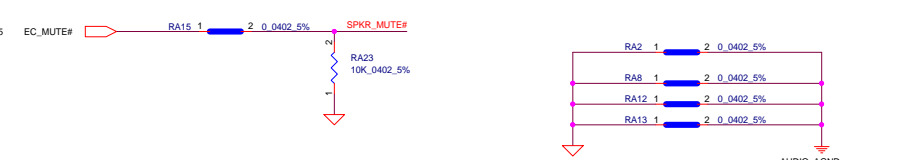

RA57 & RA59 HW BOM request from 47Ω change to 68Ω /SD00001L100, solution for HP noise issue

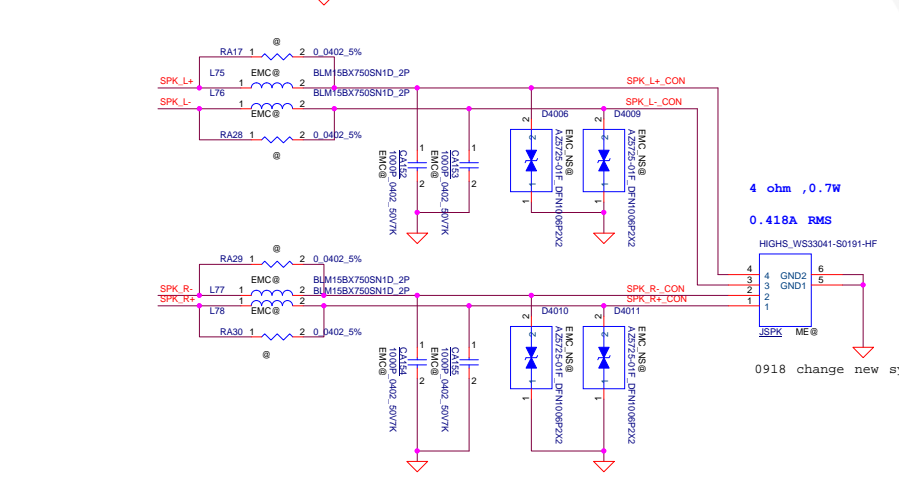

RA194,RA195,RA196,RA197 will be changed from 150ohm to 0ohm, for HW SO---->S3 play music hang up issue solut i on Place Close To Codec

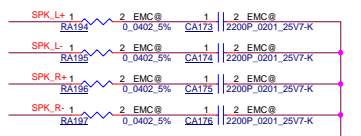

	Vendor	PN	Describe
国内	NATIONZ	SA000071N00	S IC 232H320TC-LPC-F20-233 TSSOP 28P TPM
WW 1.2	Nuvoton	SA00007RJ00	S IC NPCT650L1MX TSSOP 28P TPM1.2
WW 2.0	Nuvoton	SA00007H100	S IC NPCT650L1YX QFN 32P DISCRETE TPM
	Nuvoton	SA00007FW00	S IC NPCT650L1MX TSSOP 28P TPM 2.0

SDV Use WW2.0 Nuvoton
SIV need change to WW1.2 QFN

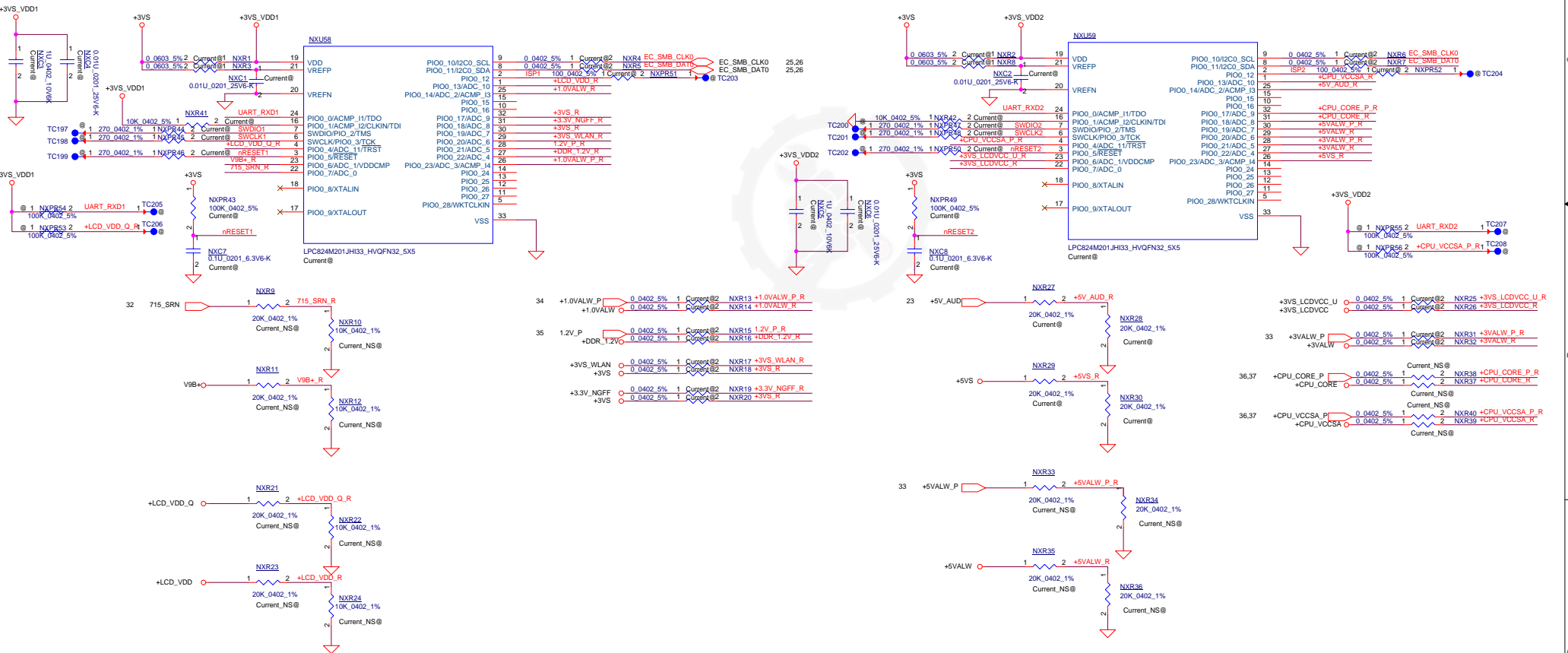
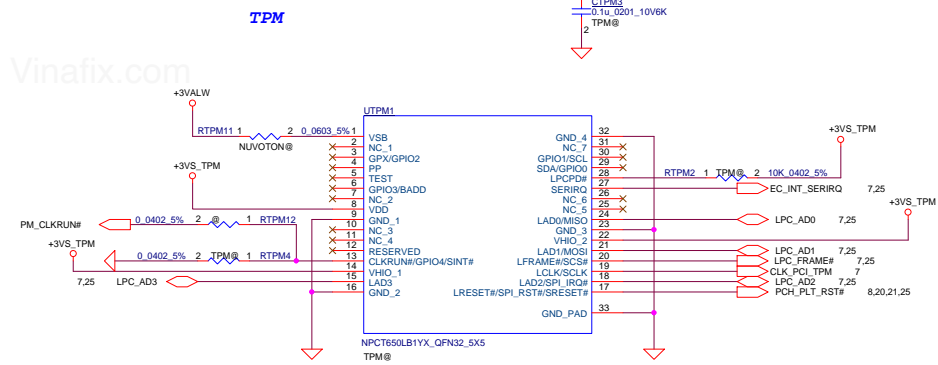

Vinafix.com

EC change to 8586 SA00005WC0J
S IC IT8586VG/ FX VFBGA128P EMBEDDED CTRL

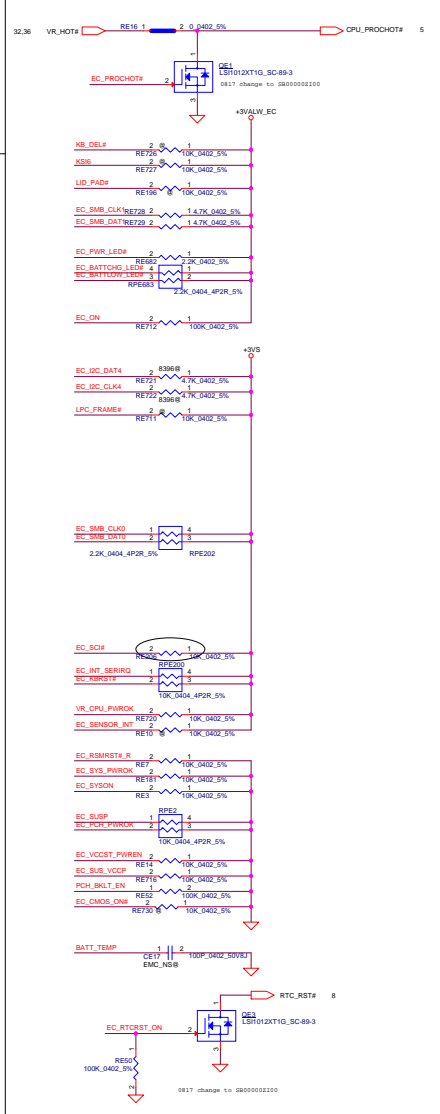
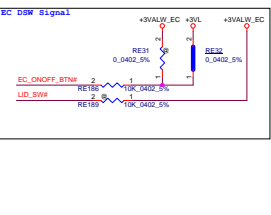
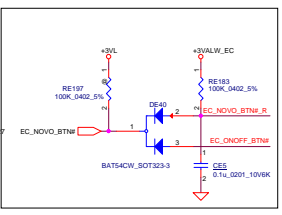
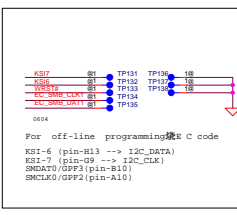
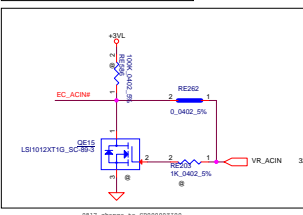
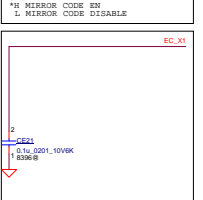
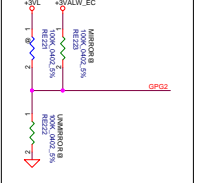
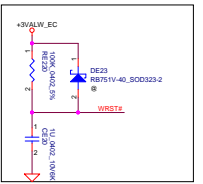
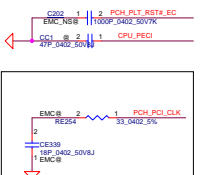
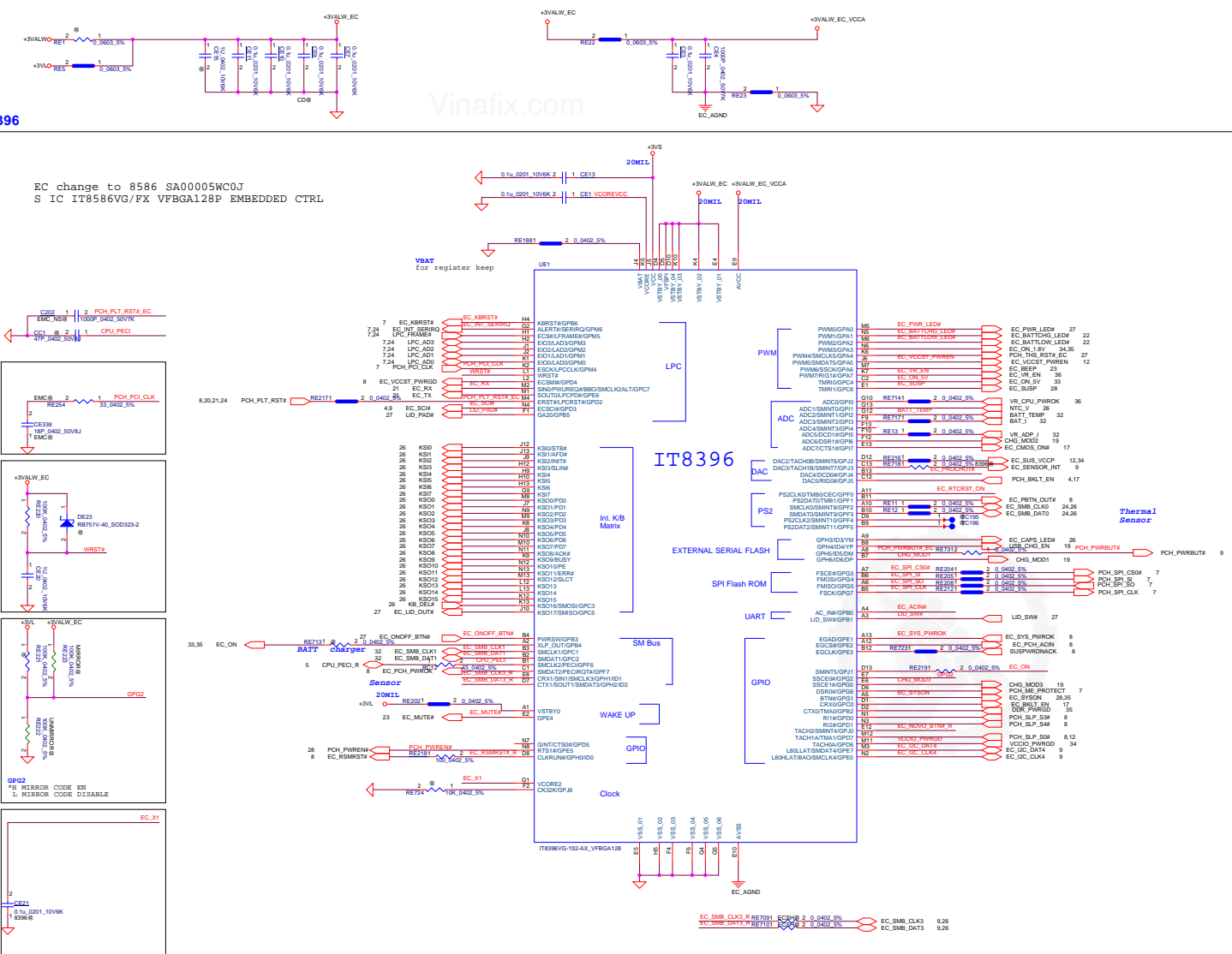

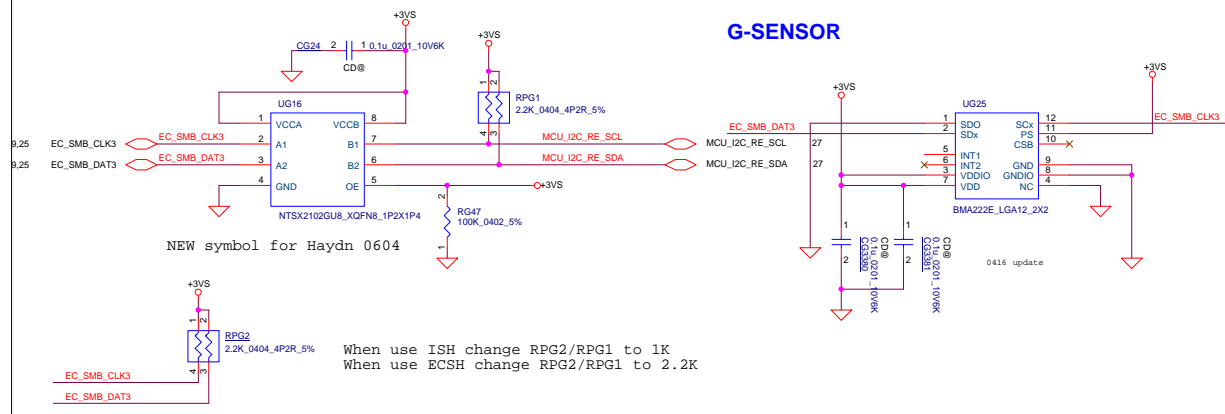

Keyboard Connector

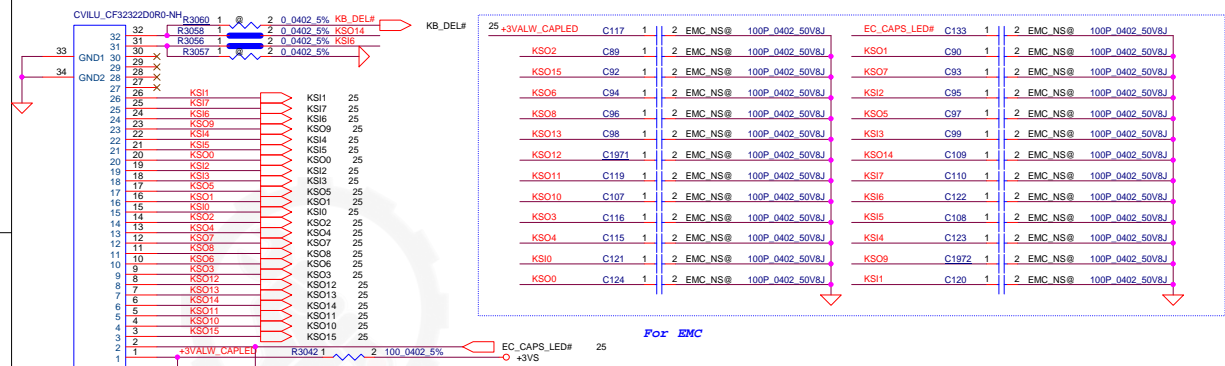

THM Sensor



Nuvoton thermal sensor

Address 1001_100xb

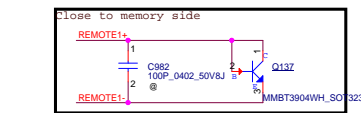
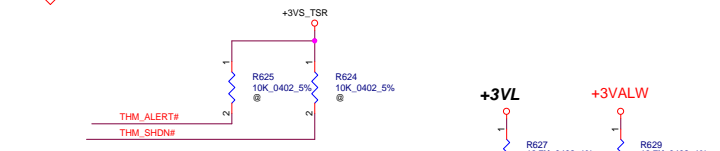
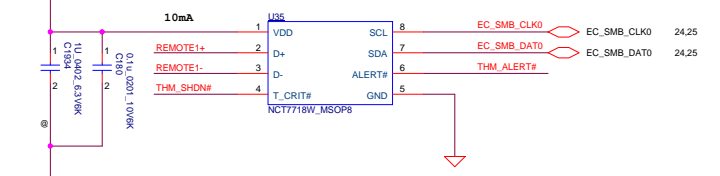

REMOTE1+/-:
Trace width/space:10/10 mil
Trace length:<8"

Touch Pad Connector

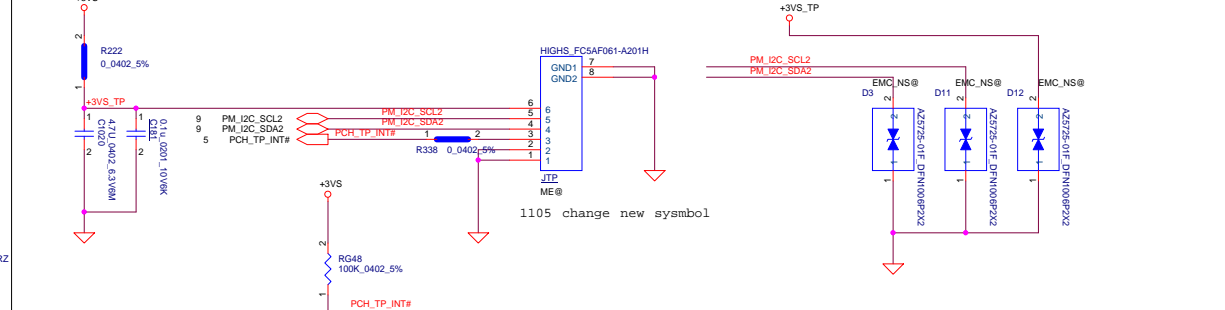

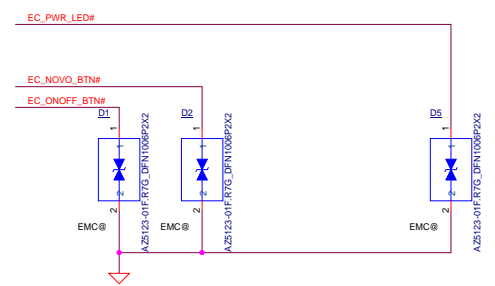
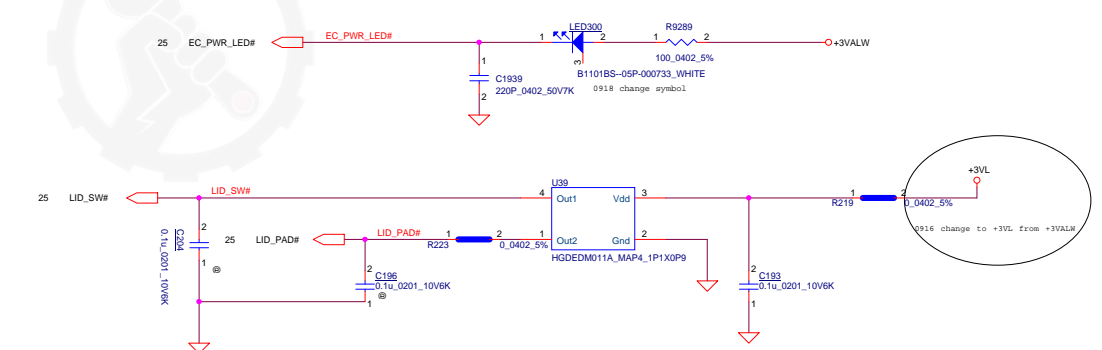
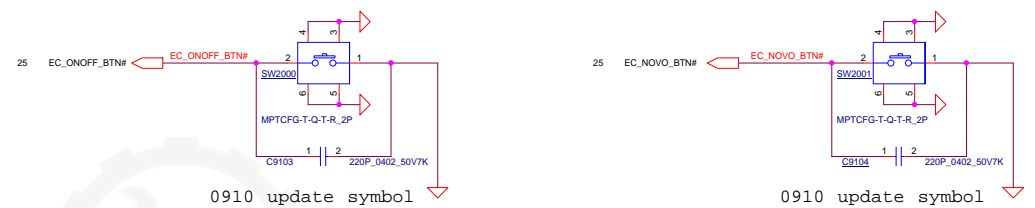
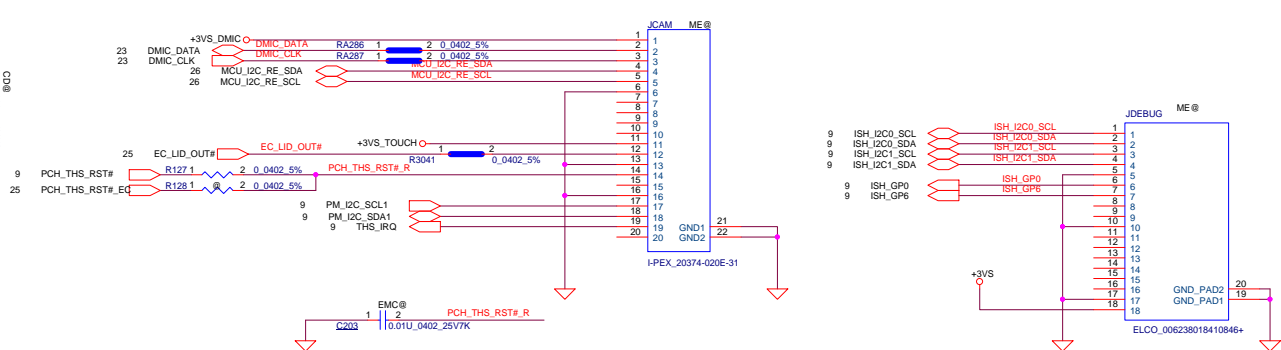
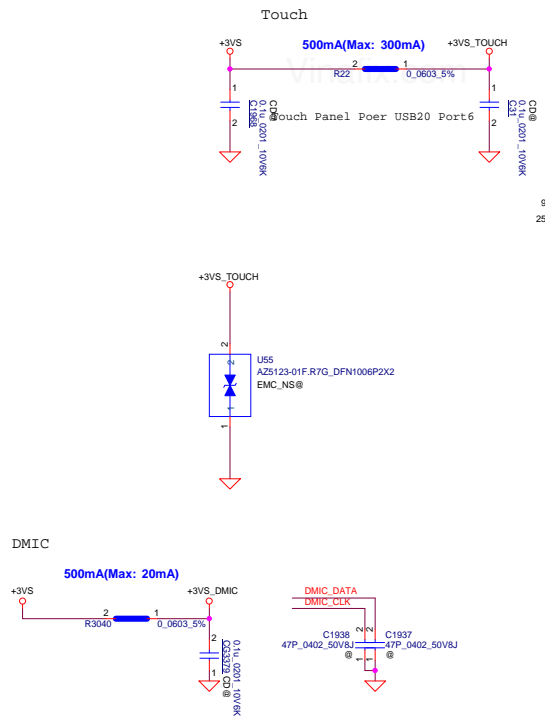

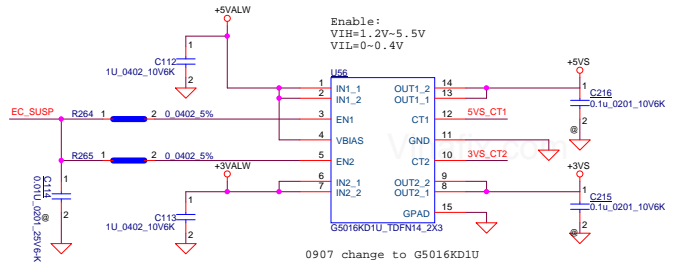

Security Classification	LC Future Center Secret Data		Title	
Issued Date	2015/11/09	Deciphered Date	2016/06/27	
THIS SHEET OF ENGINEERING DRAWING IS THE PROPRIETARY PROPERTY OF LC FUTURE CENTER, AND CONTAINS CONFIDENTIAL AND TRADE SECRET INFORMATION. THIS SHEET MAY NOT BE TRANSFERRED FROM THE CUSTODY OF THE COMPETENT DIVISION OF R&D DEPARTMENT EXCEPT AS AUTHORIZED BY LC FUTURE CENTER. NEITHER THIS SHEET NOR THE INFORMATION IT CONTAINS MAY BE USED BY OR DISCLOSED TO ANY THIRD PARTY WITHOUT PRIOR WRITTEN CONSENT OF LC FUTURE CENTER.				

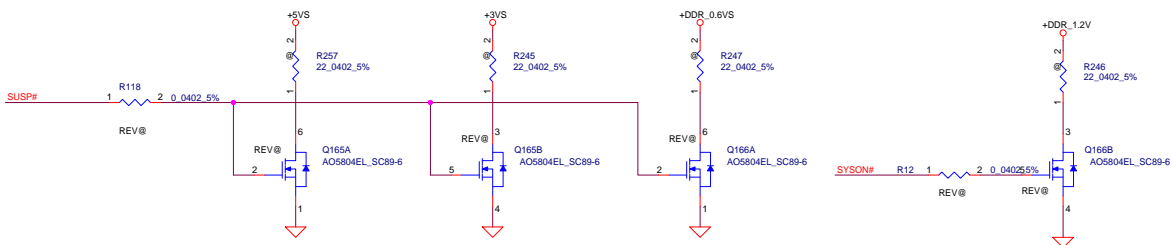
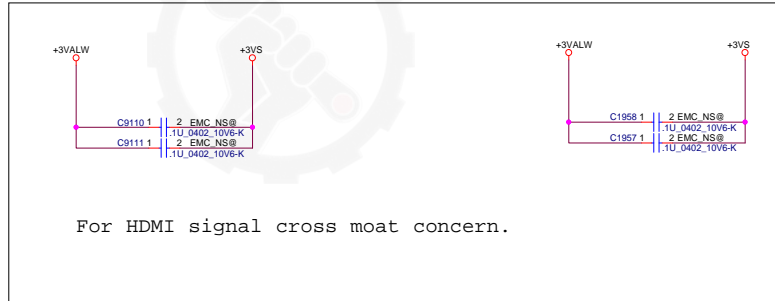
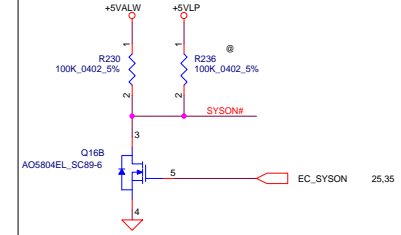
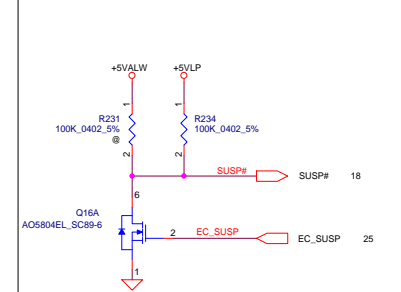
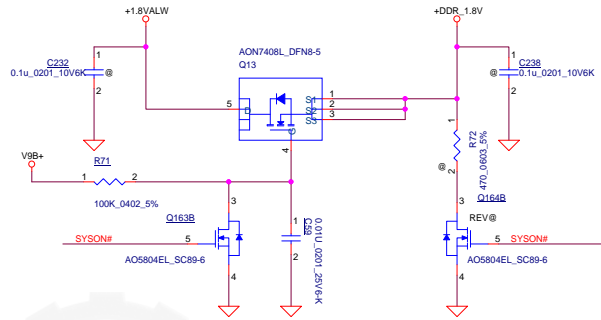
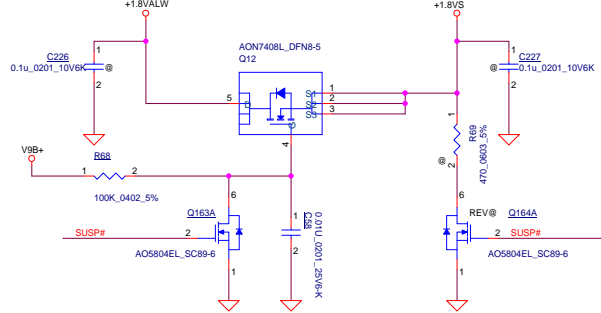
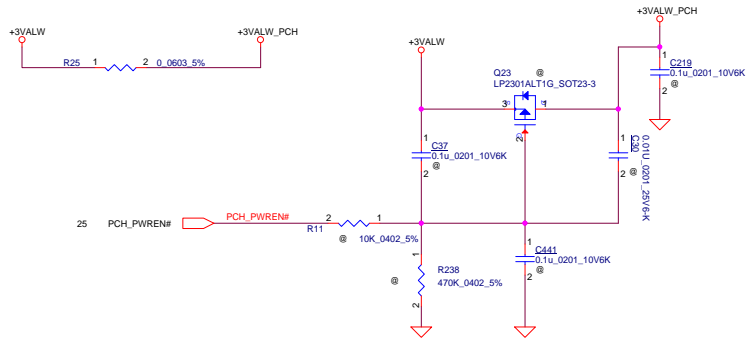
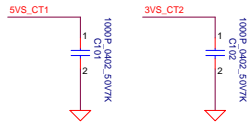

0907 change to G5016KD1U



Security Classification	LC Future Center Secret Data		Title
Issued Date	2015/11/09	Deciphered Date	2016/06/27
THIS SHEET OF ENGINEERING DRAWING IS THE PROPRIETARY PROPERTY OF LC FUTURE CENTER, AND CONTAINS CONFIDENTIAL AND TRADE SECRET INFORMATION. THIS SHEET MAY NOT BE TRANSFERRED FROM THE CUSTODY OF THE COMPETENT DIVISION OF R&D DEPARTMENT EXCEPT AS AUTHORIZED BY LC FUTURE CENTER. NEITHER THIS SHEET NOR THE INFORMATION IT CONTAINS MAY BE USED BY OR DISCLOSED TO ANY THIRD PARTY WITHOUT PRIOR WRITTEN CONSENT OF LC FUTURE CENTER.			POWER SWITCH  Size Document Number Miray-K Date: Thursday, June 23, 2016 Sheet 28 of 38 Rev 1.0

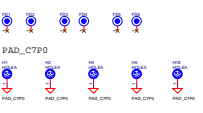

PAD_C7P0



PAD_C6P0D2P3



PAD_CT5P0D1P5



PAD_C6P5D3P4



PAD_C5P5D2P3



pad_e5p0



PAD_SHAPE3P9X2P8



PAD_SHAPE4P5X2P4



PAD_SHAPE4P0X2P1

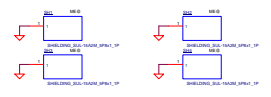

Vinafix.com





8.31
Follow DXF update Hole

Vinafix.com

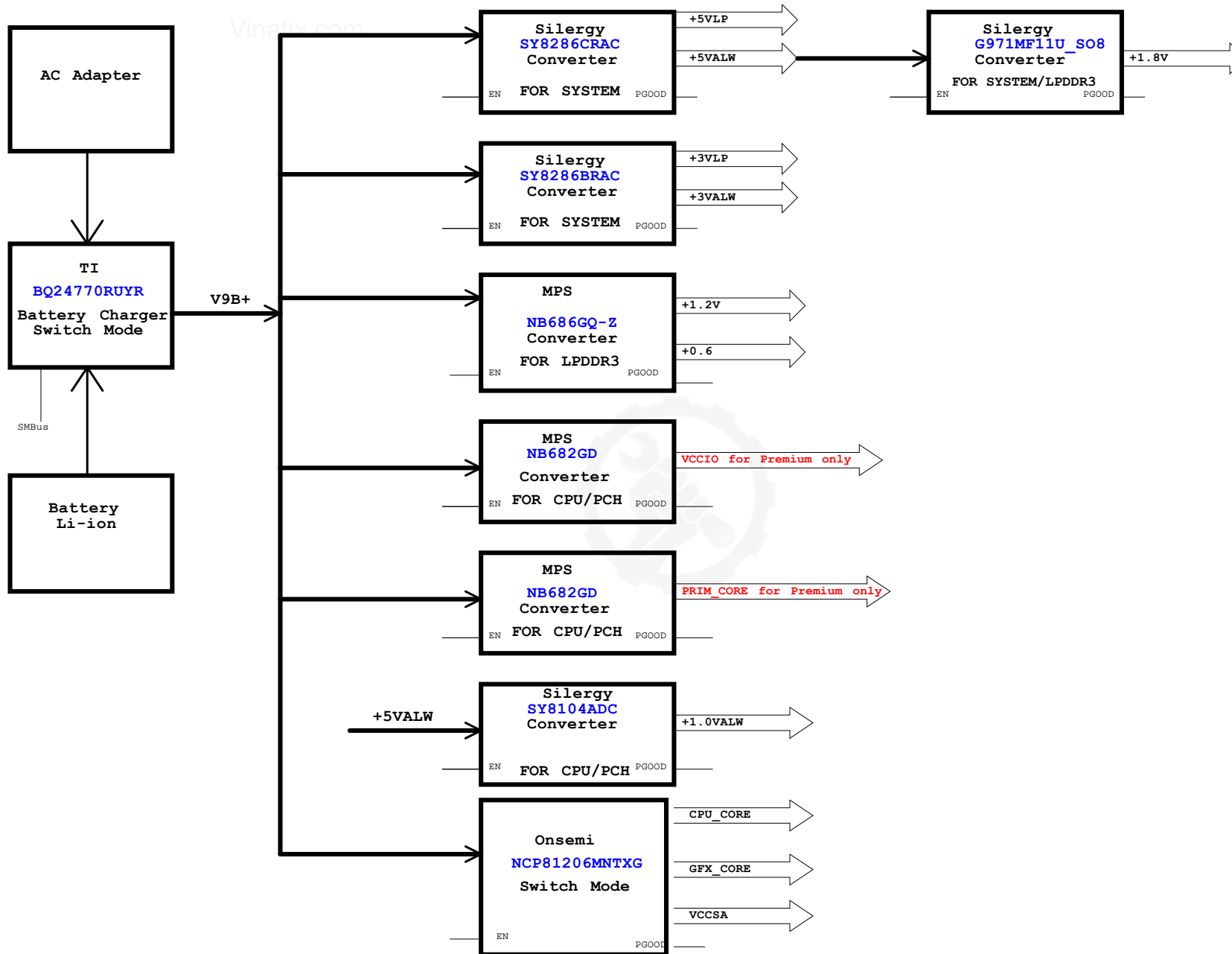

Security Classification	LC Future Center Secret Data			Title	
Issued Date	2015/11/09	Deciphered Date	2016/06/27	HW_Change_List	
<small>THIS SHEET OF ENGINEERING DRAWING IS THE PROPRIETARY PROPERTY OF LC FUTURE CENTER, AND CONTAINS CONFIDENTIAL AND TRADE SECRET INFORMATION. THIS SHEET MAY NOT BE TRANSFERRED FROM THE CUSTODY OF THE COMPETENT DIVISION OF R&D DEPARTMENT EXCEPT AS AUTHORIZED BY LC FUTURE CENTER. NEITHER THIS SHEET NOR THE INFORMATION IT CONTAINS MAY BE USED BY OR DISCLOSED TO ANY THIRD PARTY WITHOUT PRIOR WRITTEN CONSENT OF LC FUTURE CENTER.</small>					
Size	Document Number	Rev			
C	Miray-K	1.0			
Date:	Thursday, June 23, 2016	Sheet	30	of	38



Security Classification	LC Future Center Secret Data		Title
Issued Date	2015/11/09	Deciphered Date	2016/06/27
<small>THIS SHEET OF ENGINEERING DRAWING IS THE PROPRIETARY PROPERTY OF LC FUTURE CENTER, AND CONTAINS CONFIDENTIAL AND TRADE SECRET INFORMATION. THIS SHEET MAY NOT BE TRANSFERRED FROM THE CUSTODY OF THE COMPETENT DIVISION OF R&D DEPARTMENT EXCEPT AS AUTHORIZED BY LC FUTURE CENTER. NEITHER THIS SHEET NOR THE INFORMATION IT CONTAINS MAY BE USED BY OR DISCLOSED TO ANY THIRD PARTY WITHOUT PRIOR WRITTEN CONSENT OF LC FUTURE CENTER.</small>			NVDC Charger  Miray-K
Size	Document Number	Rev	1.0
Date:	Thursday, June 23, 2016	Sheet	31 of 38

Vinafix.com

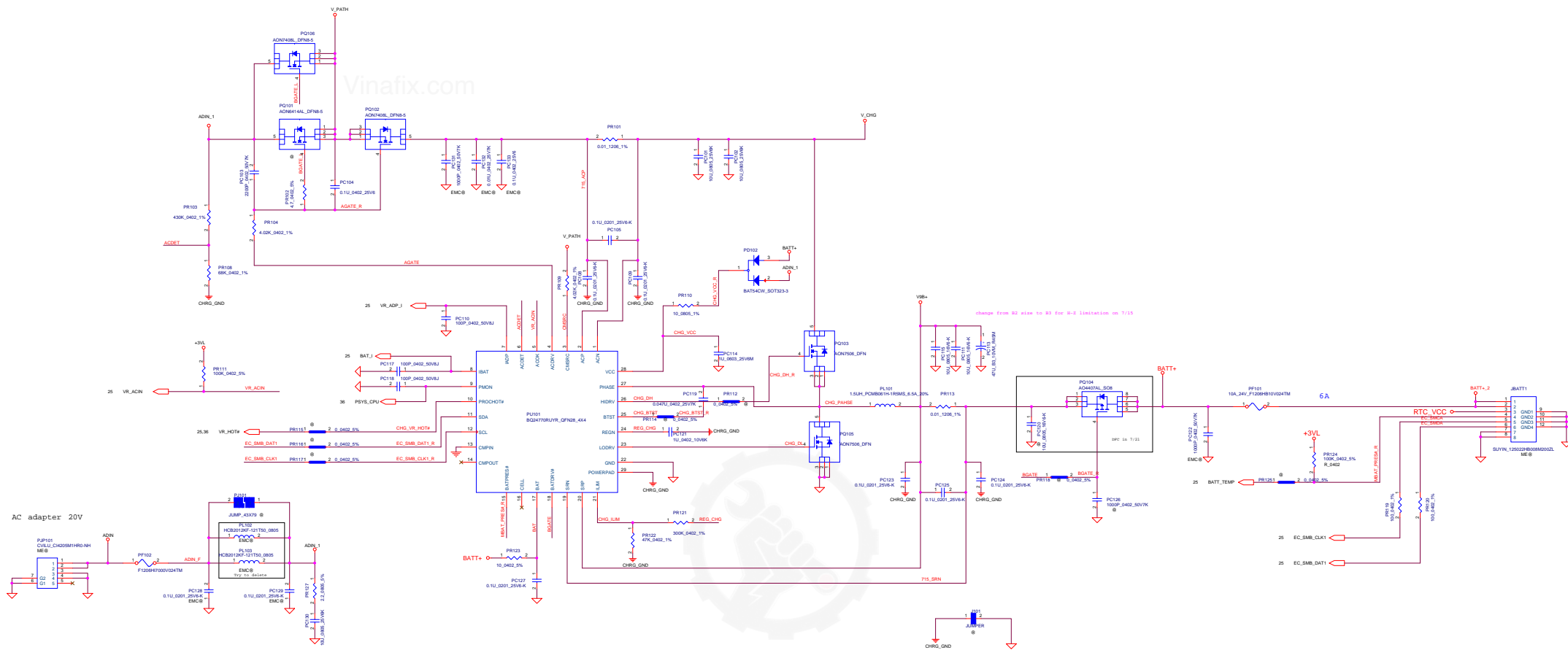

001

Security Classification	LC Future Center Secret Data	Title	PWR_NVDC Charger
Issued Date	2015/1/09	Dispatched Date	2016/06/27
Doc No		Doc No	
Rev		Rev	
Issue		Issue	
Drawn		Drawn	
Checked		Checked	
Approved		Approved	
Released		Released	
Rev		Rev	
Issue		Issue	
Drawn		Drawn	
Checked		Checked	
Approved		Approved	
Released		Released	

THIS SHEET OF ENGINEERING DRAWING IS THE PROPRIETARY PROPERTY OF LC FUTURE CENTER AND CONTAINS CONFIDENTIAL AND TRADE SECRET INFORMATION. THIS SHEET MAY NOT BE REPRODUCED OR TRANSMITTED IN ANY FORM OR BY ANY MEANS, ELECTRONIC OR MECHANICAL, INCLUDING PHOTOCOPYING, RECORDING, OR BY ANY INFORMATION STORAGE AND RETRIEVAL SYSTEM, WITHOUT THE WRITTEN PERMISSION OF LC FUTURE CENTER.

LCFC

Nixray-K

1.0

Thursday, April 23, 2016

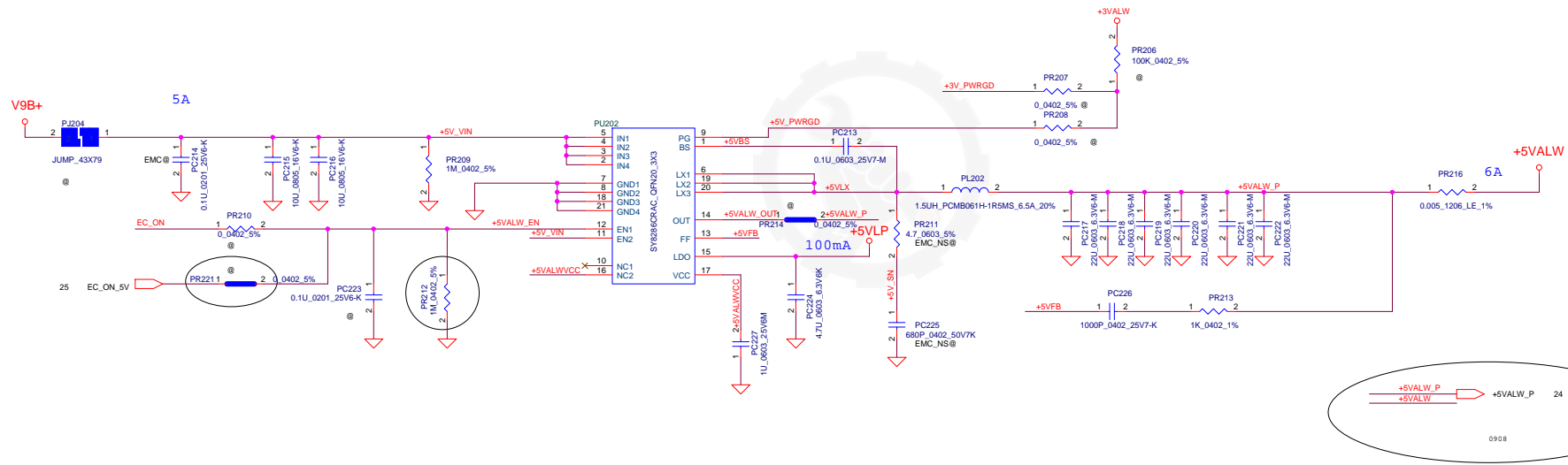
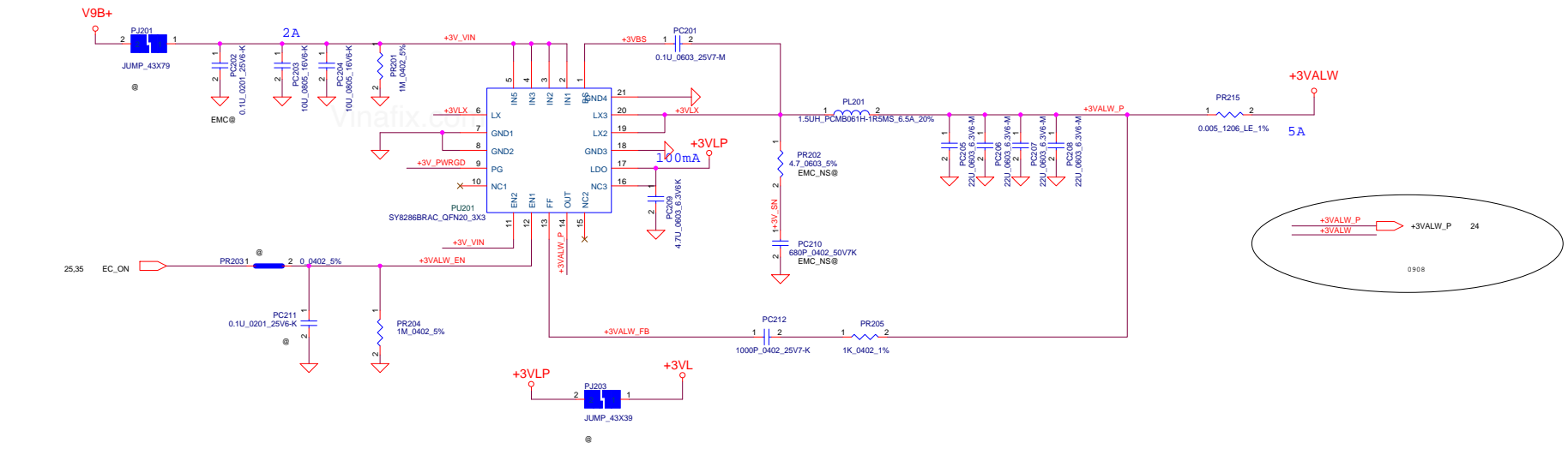

Security Classification		LC Future Center Secret Data		Title	
Issued Date	2015/11/09	Deciphered Date	2016/06/27	3VALWP/5VALWP	
THIS SHEET OF ENGINEERING DRAWING IS THE PROPRIETARY PROPERTY OF LC FUTURE CENTER, AND CONTAINS CONFIDENTIAL AND TRADE SECRET INFORMATION. THIS SHEET MAY NOT BE TRANSFERRED FROM THE CUSTODY OF THE COMPETENT DIVISION OF R&D DEPARTMENT EXCEPT AS AUTHORIZED BY LC FUTURE CENTER. NEITHER THIS SHEET NOR THE INFORMATION IT CONTAINS MAY BE USED BY OR DISCLOSED TO ANY THIRD PARTY WITHOUT PRIOR WRITTEN CONSENT OF LC FUTURE CENTER.					
Size	Document Number				Rev
Date:	Thursday, June 23, 2016				1.0
	Sheet 33 of 38				

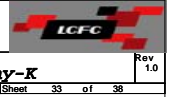

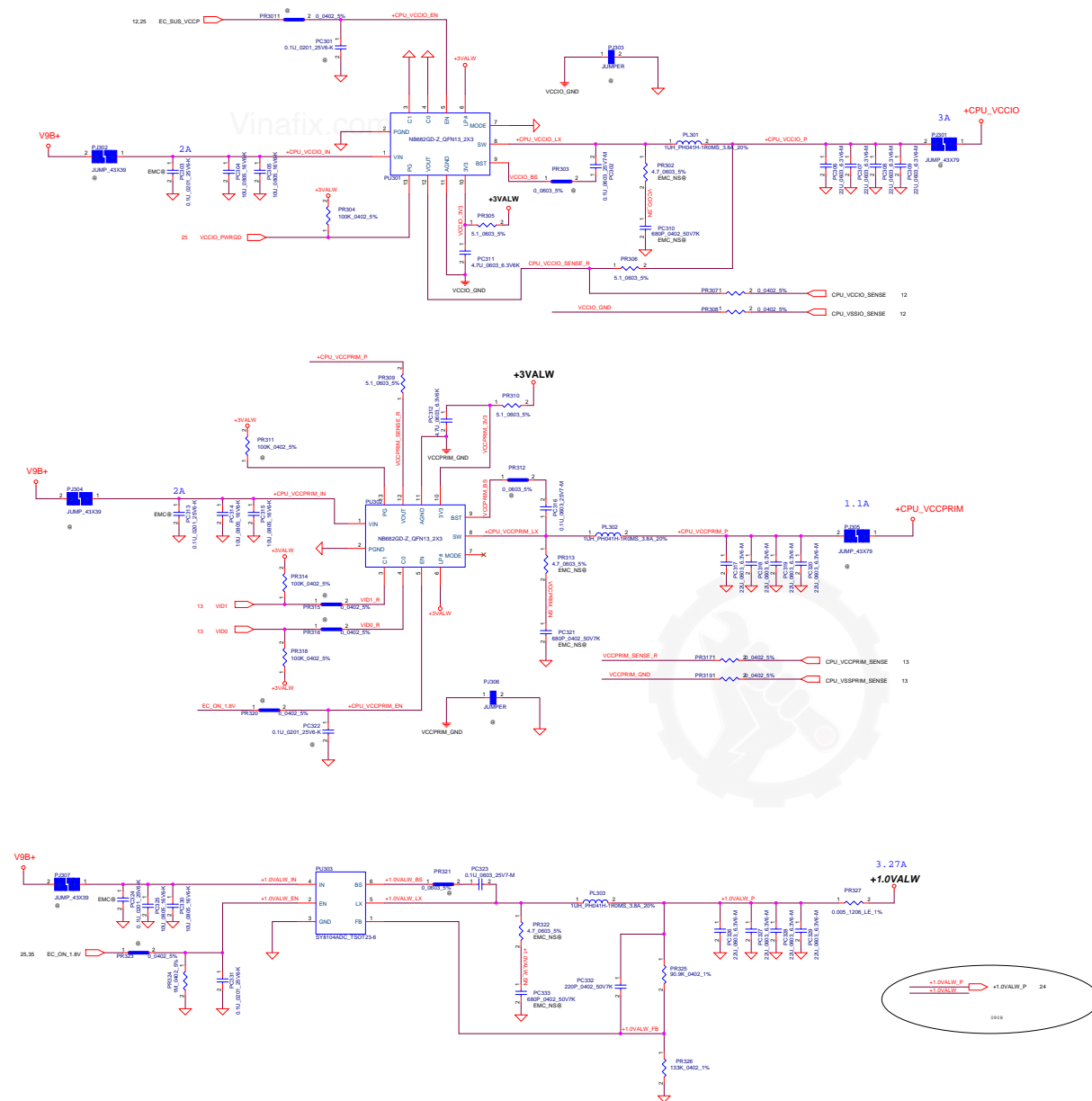

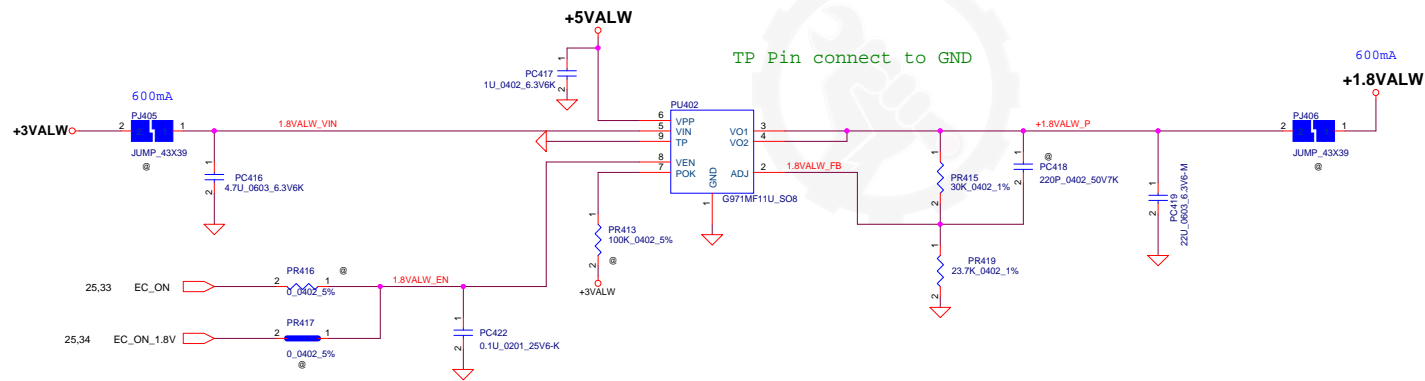
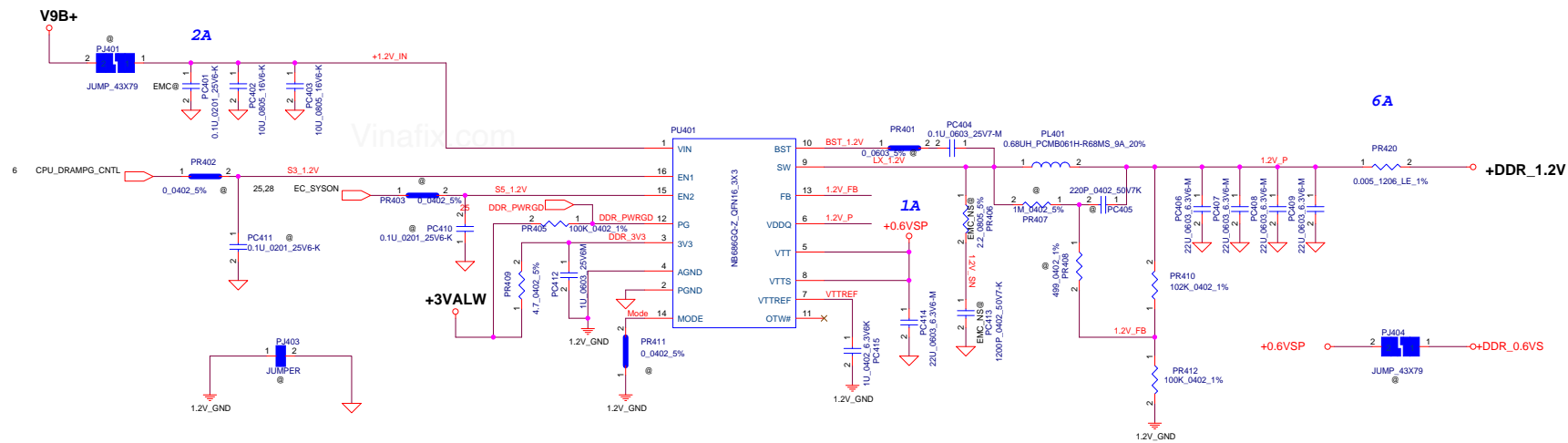

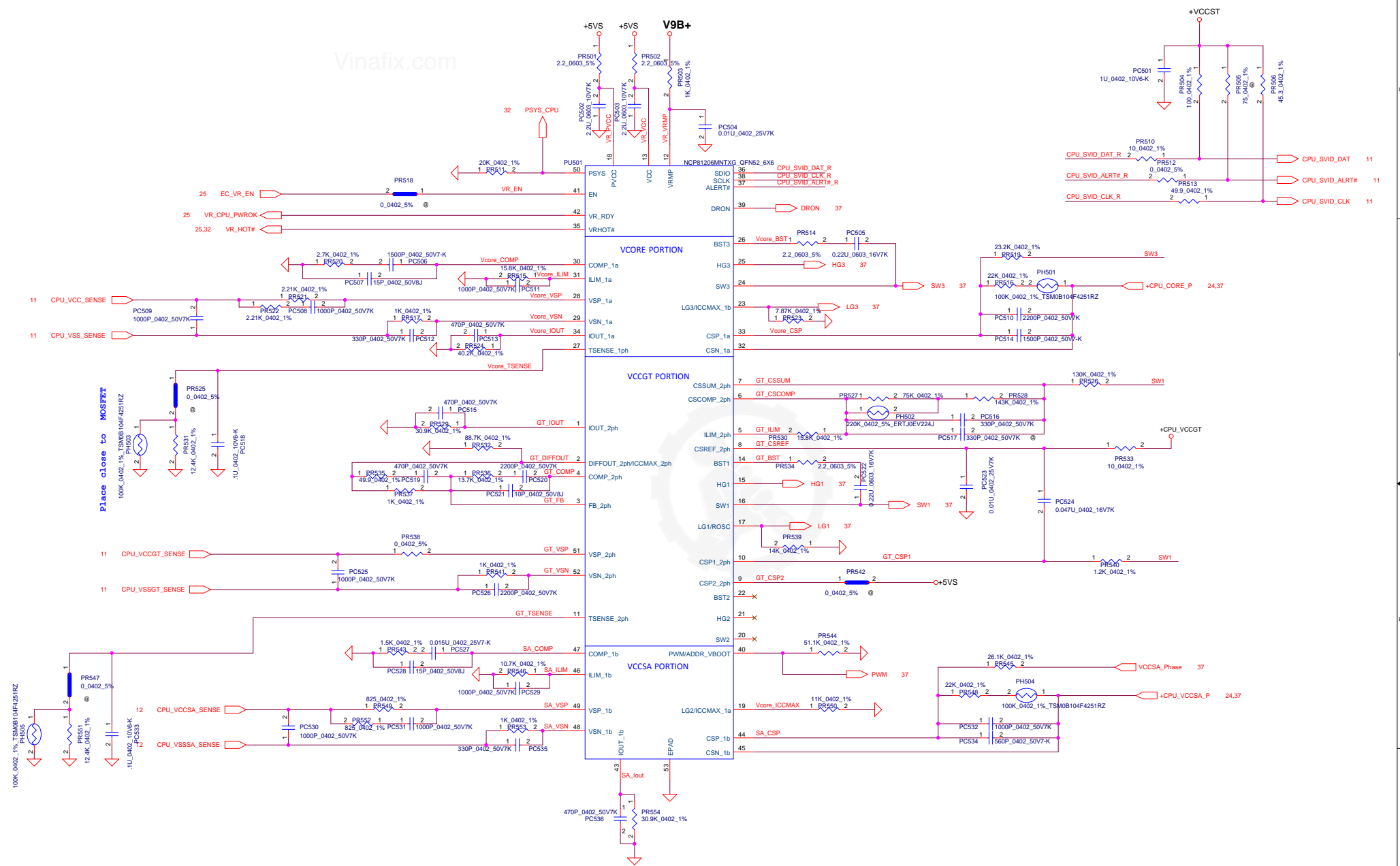

Place close to MOSFET

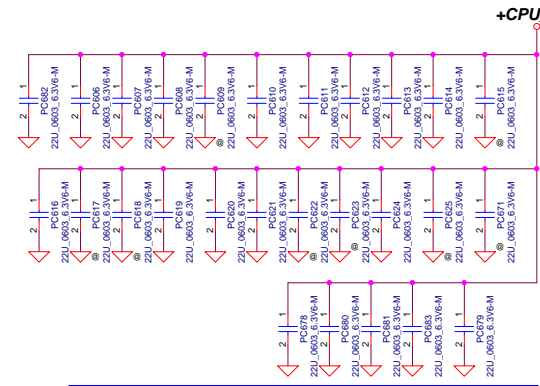
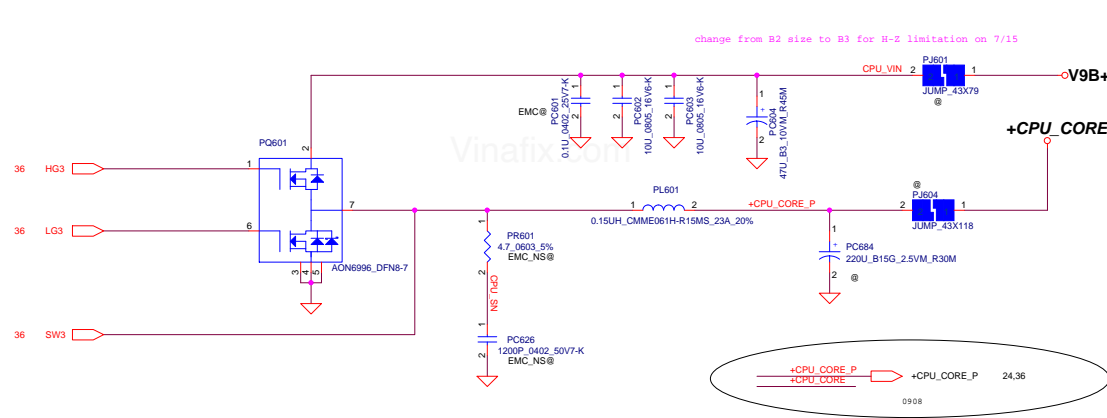

TDC=15A
 I_{max}=24A
 LL=4.7mohm
 OCP=37A

NC PC609,PC671,PC623,PC618,PC625 for DFC
 11/5: NC PC617,PC622,PC615 for cost down

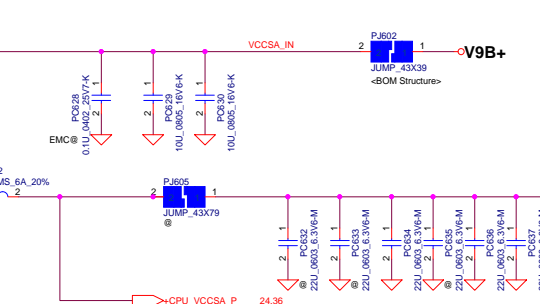
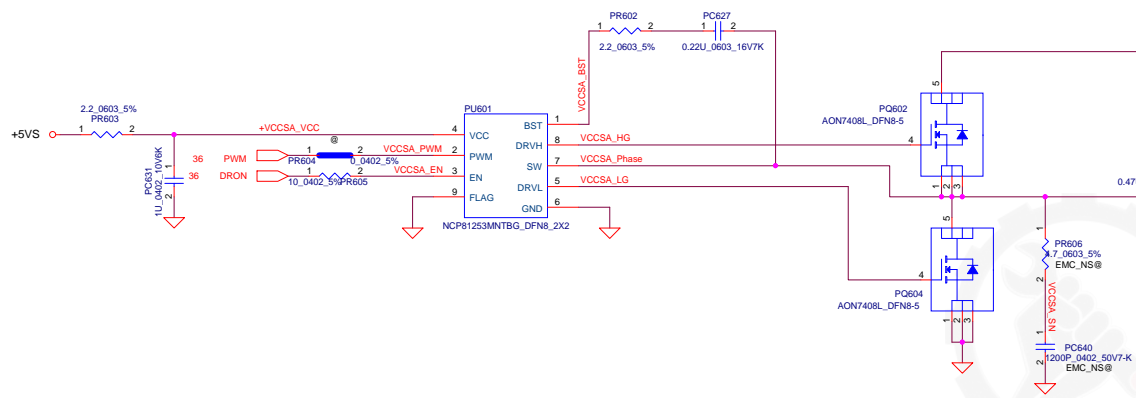

TDC=4A
 I_{max}=4.1A
 LL=14mohm
 OCP=10A

NC PC632 for DFC
 11/5: NC PC633,PC635,PC673 for cost down

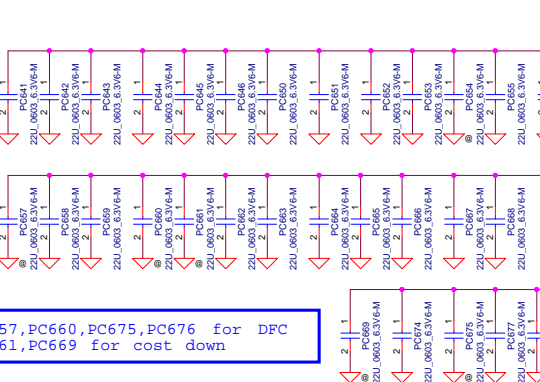
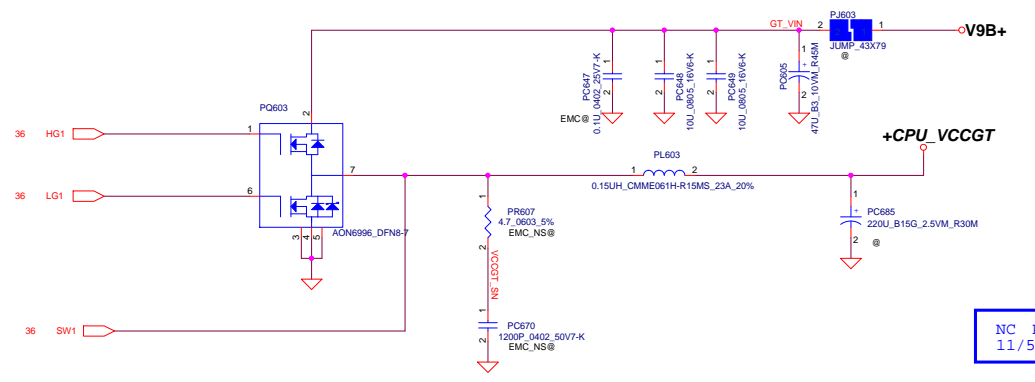

TDC=14A
 I_{max}=24A
 LL=4.2mohm
 OCP=37A

NC PC654,PC657,PC660,PC675,PC676 for DFC
 11/5: NC PC661,PC669 for cost down

Vinafix.com



Security Classification	LC Future Center Secret Data			Title				
Issued Date	2015/11/09	Deciphered Date	2016/06/27	IMVP8				
<small>THIS SHEET OF ENGINEERING DRAWING IS THE PROPRIETARY PROPERTY OF LC FUTURE CENTER, AND CONTAINS CONFIDENTIAL AND TRADE SECRET INFORMATION. THIS SHEET MAY NOT BE TRANSFERRED FROM THE CUSTODY OF THE COMPETENT DIVISION OF R&D DEPARTMENT EXCEPT AS AUTHORIZED BY LC FUTURE CENTER. NEITHER THIS SHEET NOR THE INFORMATION IT CONTAINS MAY BE USED BY OR DISCLOSED TO ANY THIRD PARTY WITHOUT PRIOR WRITTEN CONSENT OF LC FUTURE CENTER.</small>					Size	Document Number	Rev	
					Date:	Thursday, June 23, 2016	Sheet 38 of 38	1.0